

Model THC0507H

Features

Excellent phase & amplitude balance
Low Insertion Loss & VSWR
High Isolation

Technical Data Sheet			
Frequency Range	500~700MHz	Finish	Painted Blue_ RAL #5007
Nominal Split	3.01dB	Connector Body	Brass, Tri-Alloy Plate
Insertion Loss	≤0.4dB	Housing	Aluminum, 6061 T6 Clear Chem Conversion Film
Isolation	≥20dB		
Amplitude Balance	≤±0.4dB	Connector Pin	Beryllium Copper, Gold Plate
Phase Balance	≤±4°	Solder	Lead Free, RoHS Compliant
VSWR	≤1.30:1	Operating Temperature	-55~+85°C
¹ Power Handling	Average ≤200Watt Peak ≤1KW	Operating Humidity	Up to 95%, Non- Condensing
Impedance	50Ω	Weight	
Port Connectors	N-Female		

¹Power Handling guaranteed when load's VSWR within 1.50:1.

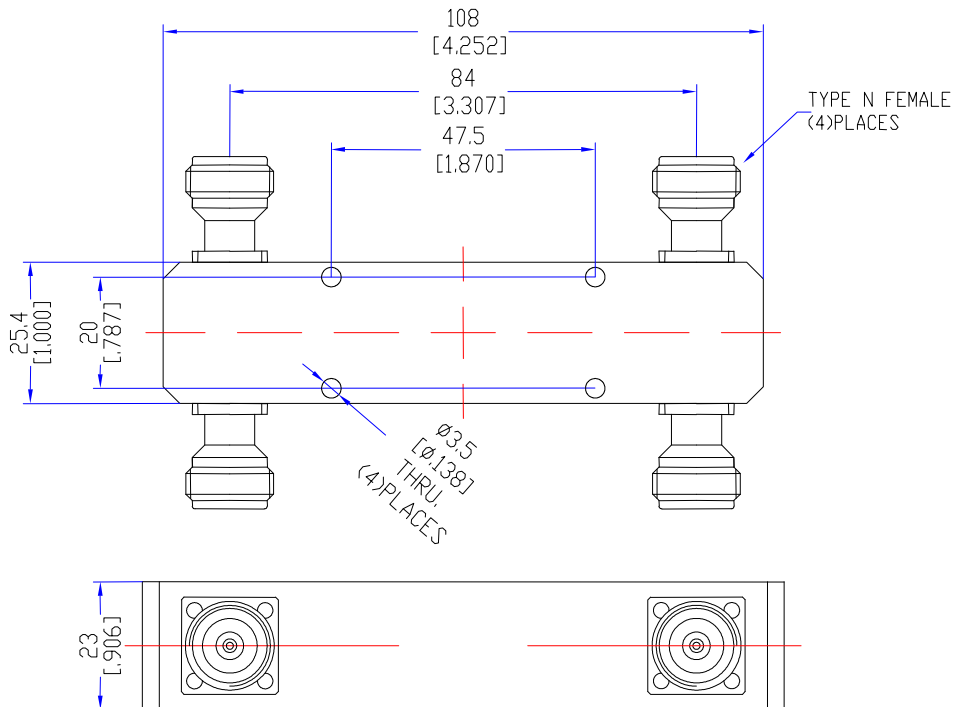

Typical Performance

1. Insertion Loss, Amplitude & Phase Balance, VSWR

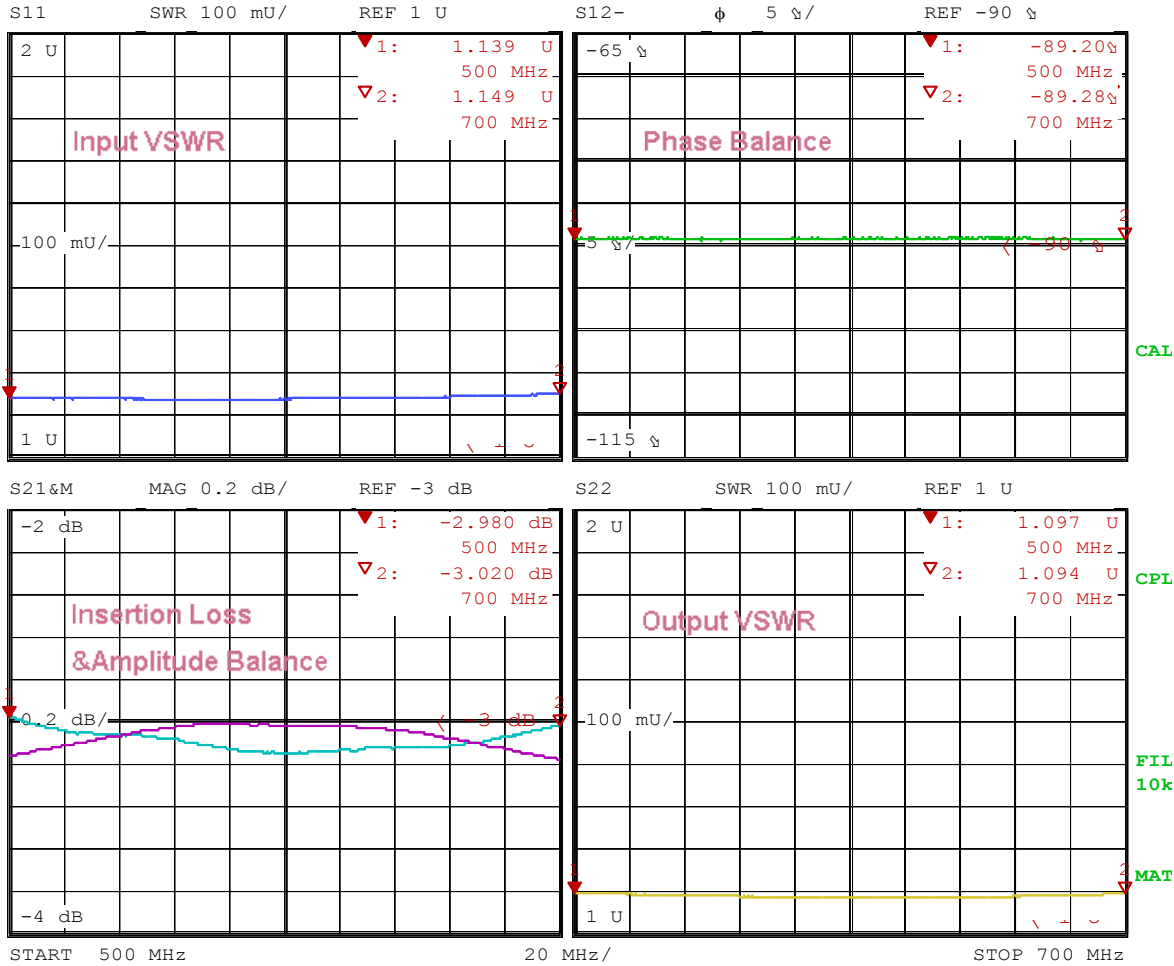

Date: 21.MAY.17 06:18:05

2. Isolation

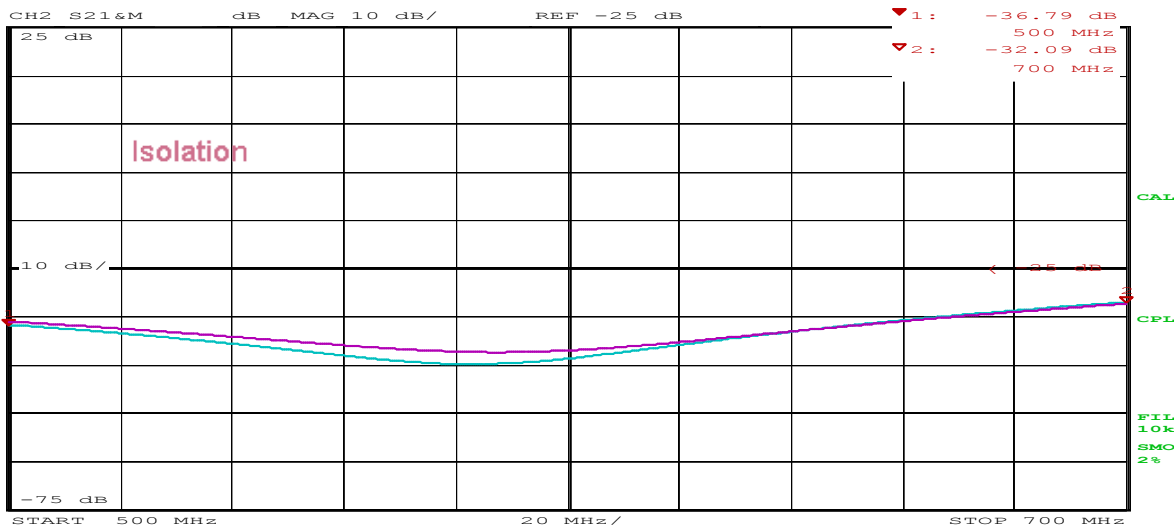

Date: 21.MAY.17 06:19:58

