

Model THC10124A1

Features

Excellent phase & amplitude balance
Low Insertion Loss & VSWR
High Isolation

Technical Data Sheet			
Frequency Range	1~12.4GHz	Finish	Painted Blue_ RAL #5007
Nominal Split	3.01dB	Connector Body	Passivated Stainless Steel
Insertion Loss	≤1.0dB	Housing	Aluminum, 6061 T6 Clear Chem Conversion Film
Isolation	≥20dB ≥22dB@1-3GHz		
Amplitude Balance	≤±0.6dB	Connector Pin	Beryllium Copper, Gold Plate
Phase Balance	≤±5°	Solder	Lead Free, RoHS Compliant
VSWR	≤1.30:1	Operating Temperature	-55~+85°C
¹ Power Handling	Average ≤50Watt Peak ≤1KW	Operating Humidity	Up to 95%, Non-Condensing
Impedance	50Ω	Weight	100g
Port Connectors	SMA-Female		

¹Power Handling guaranteed when load's VSWR within 1.50:1.

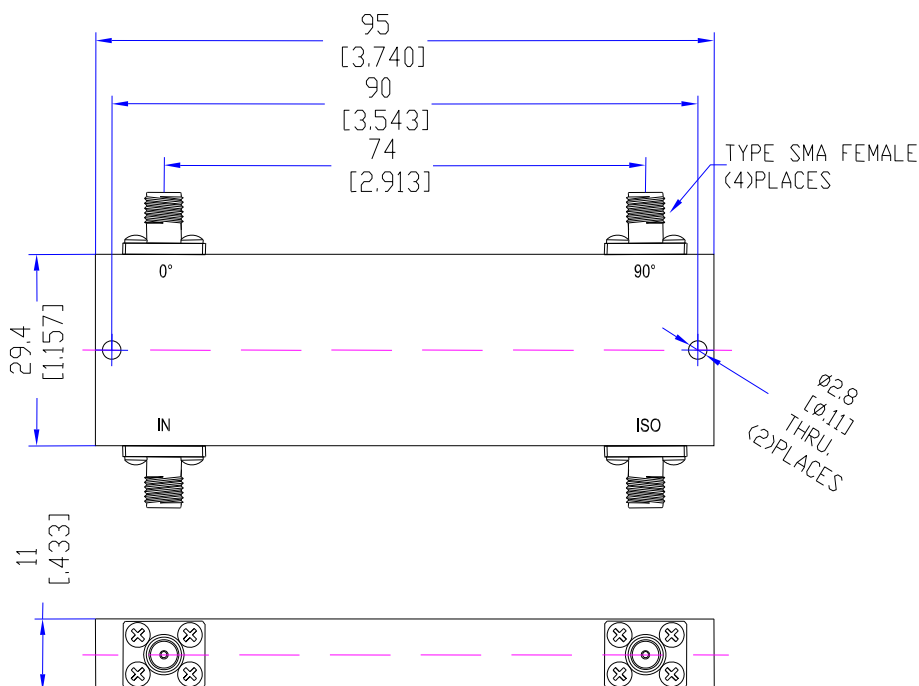

Typical Performance

1. Insertion Loss, Amplitude & Phase Balance, VSWR

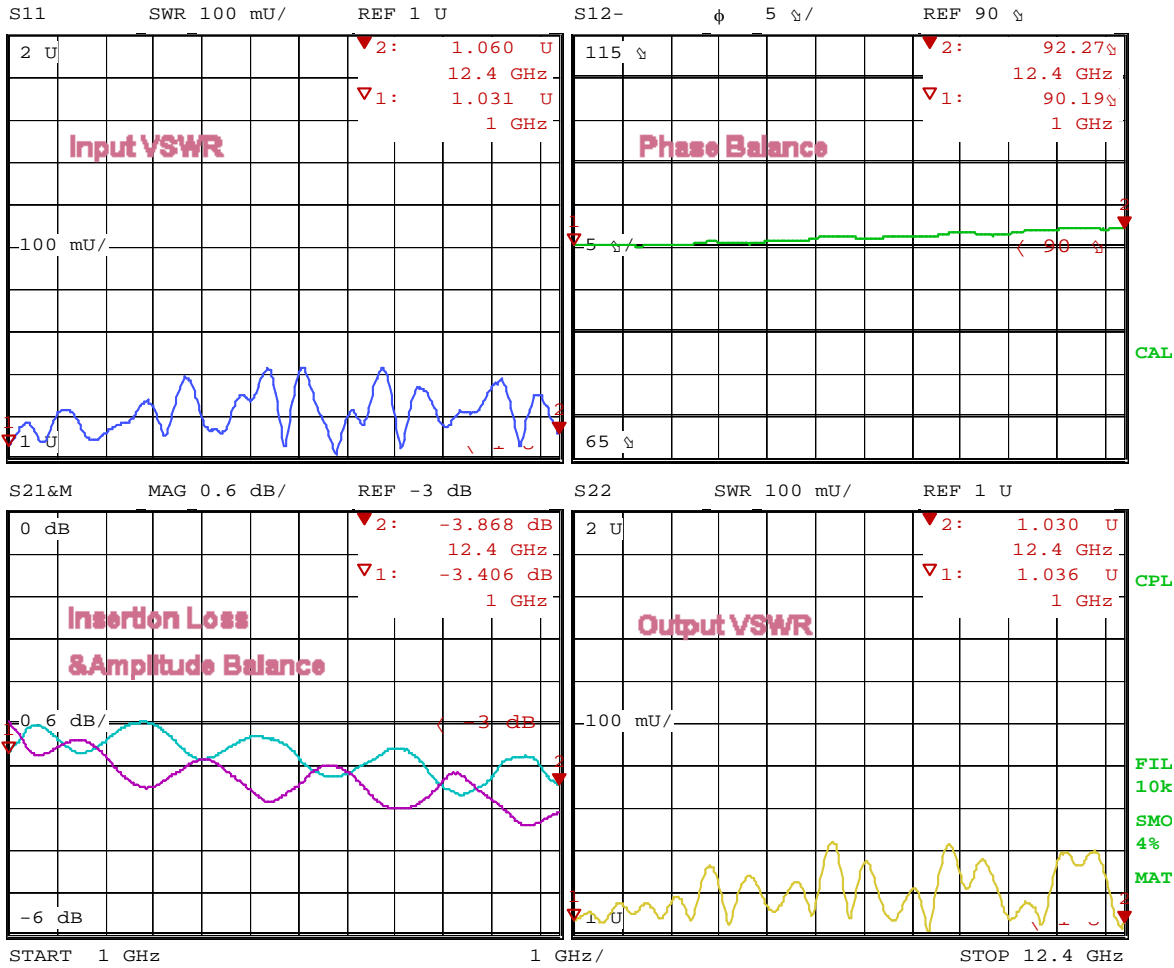

Date: 5.AUG.16 17:03:39

2. Isolation

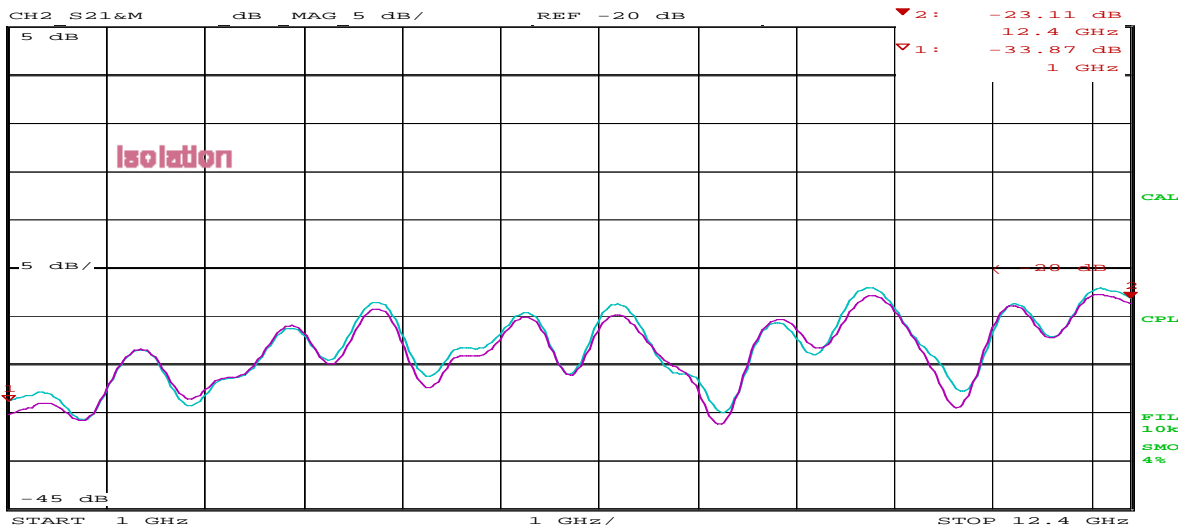

Date: 5.AUG.16 17:01:51

