

## Model TPD0760N4M

### Features

- Excellent phase& amplitude balance
- Low Insertion Loss& VSWR
- High Isolation

Technical Data Sheet			
Frequency Range	0.7~6GHz	Finish	Painted Blue_ RAL #5007
Insertion Loss	≤1.8dB (Above 6.02dB Split)	Connector Body	Brass, Tri-Alloy Plate
VSWR	Input ≤1.60:1 Output ≤1.50:1	Housing	Aluminum, 6061 T6 Clear Chem Conversion Film
Isolation	≥16dB	Connector Pin	Beryllium Copper, Gold Plate
Amplitude Balance	≤±0.5dB	Solder	Lead Free, RoHS Compliant
Phase Balance	≤±5°	Operating Temperature	-55~+85°C
<sup>1</sup> Power Handling	Forward ≤30Watt; Reversed ≤1Watt	Operating Humidity	Up to 95%, Non- Condensing
Impedance	50Ω	Weight	920g
Port Connectors	Input: N-Male Output: N-Female		

<sup>1</sup>Power Handling guaranteed when load's VSWR within 1.50:1.

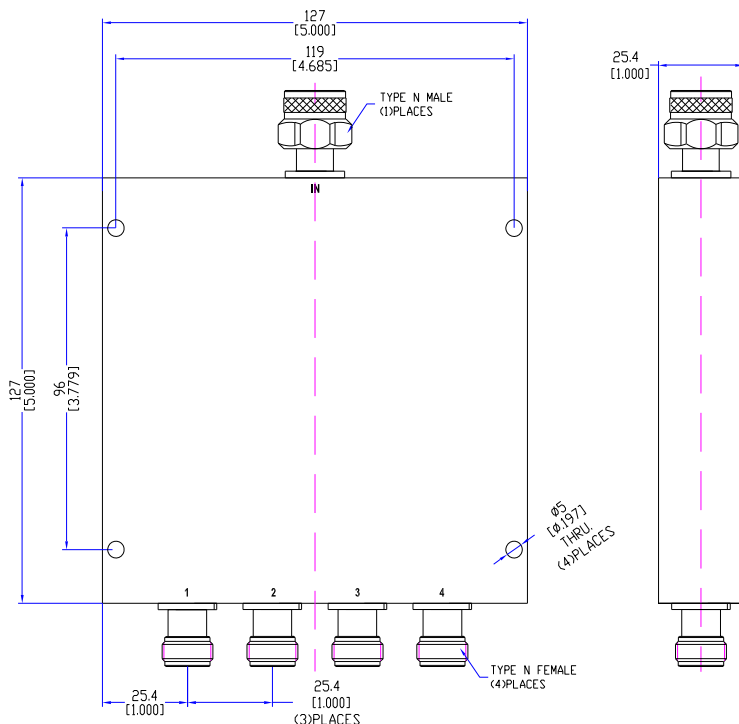

## Typical Performance

### 1. Insertion Loss, Amplitude & Phase Balance, VSWR

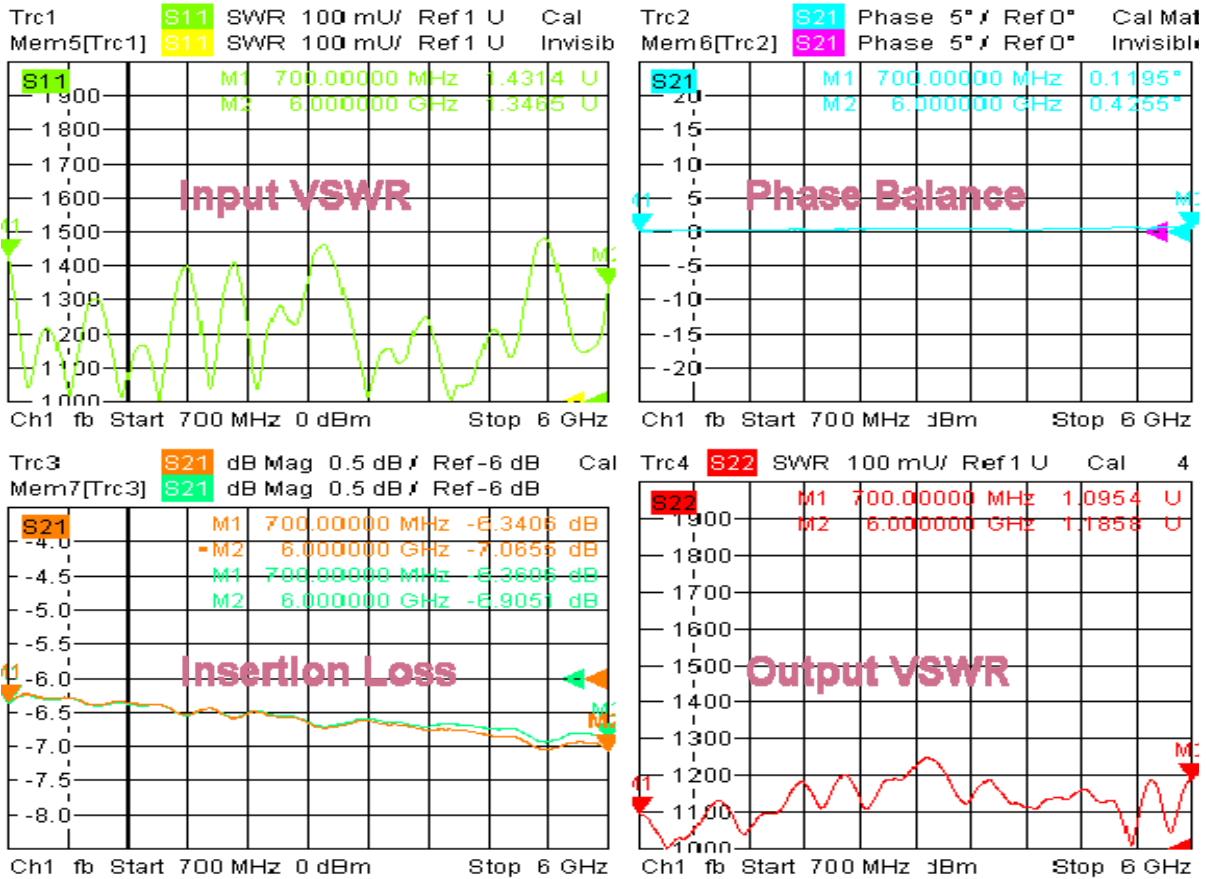

### 2. Isolation

