

Model TPD3060N2

Features

Excellent phase & amplitude balance
 Low Insertion Loss & VSWR
 High Isolation

Technical Data Sheet			
Frequency Range	3~6GHz	Finish	Painted Blue_ RAL #5007
Insertion Loss	≤0.8dB (Above 3.01dB Split)	Connector Body	Brass, Tri-Alloy Plate
VSWR	Input ≤1.40:1 Output ≤1.30:1	Housing	Aluminum, 6061 T6 Clear Chem Conversion Film
Isolation	≥20dB	Connector Pin	Beryllium Copper, Gold Plate
Amplitude Balance	≤±0.2dB	Solder	Lead Free, RoHS Compliant
Phase Balance	≤±2°	Operating Temperature	-55~+85°C
¹ Power Handling	Forward ≤30Watt; Reversed ≤1Watt	Operating Humidity	Up to 95%, Non-Condensing
Impedance	50Ω	Weight	120g
Port Connectors	N-Female		

¹Power Handling guaranteed when load's VSWR within 1.50:1.

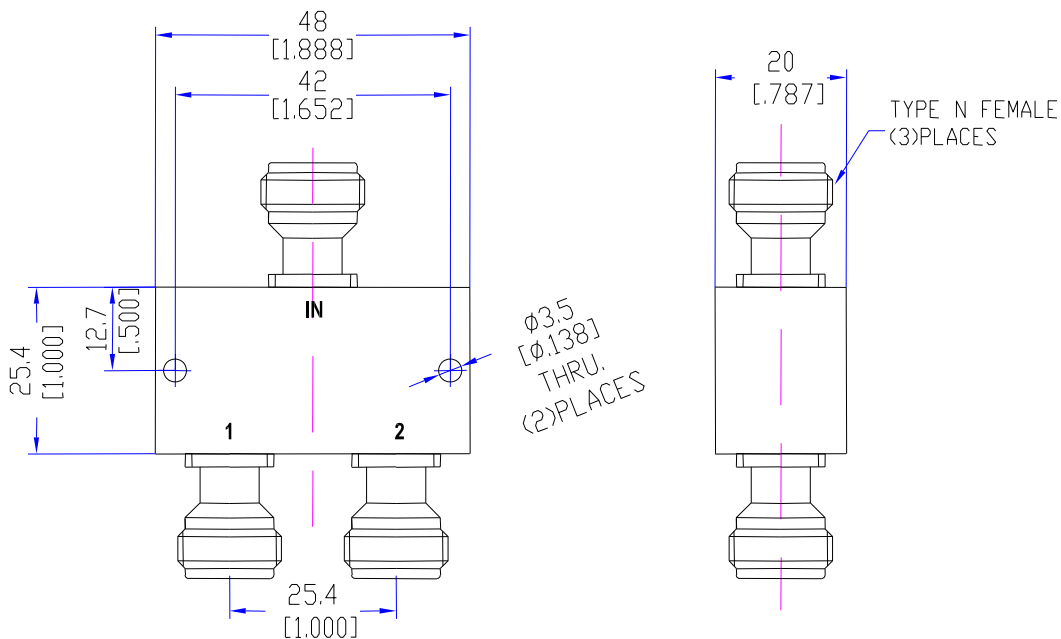

Typical Performance

1. Insertion Loss, Amplitude & Phase Balance, VSWR

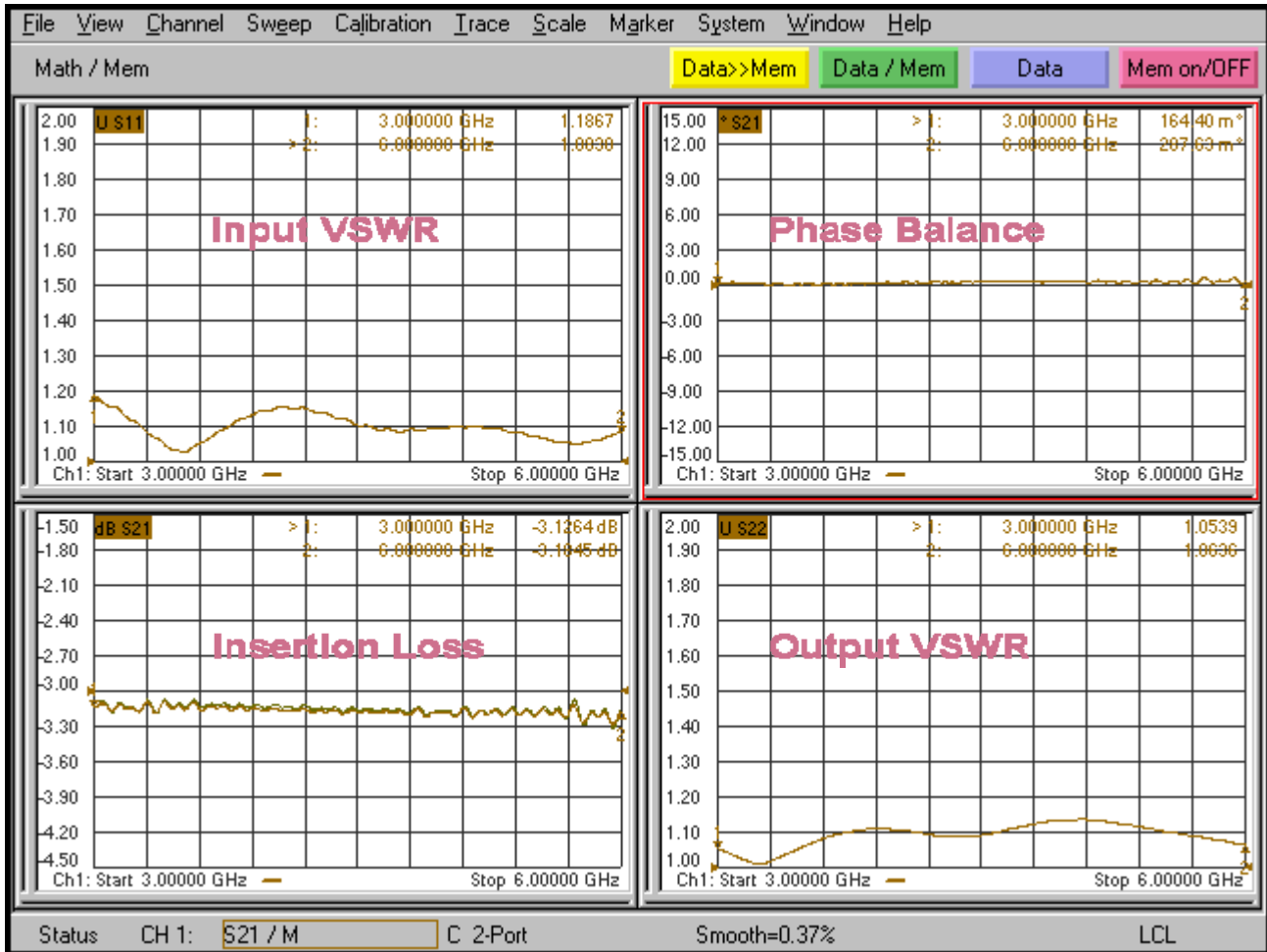

2. Insertion Loss

