

TDC10180A20D

Features

Low VSWR
High Directivity
Broadband & Miniature Size

Technical Data Sheet			
Frequency Range	1~18GHz	Finish	Painted Blue_ RAL #5007
Insertion Loss	≤1.8dB (Excl. Coupling Loss 0.08dB)	Connector Body	Passivated Stainless Steel
Coupling Factor	≤20±1dB	Housing	Aluminum, 6061 T6 Clear Chem Conversion Film
Coupling Sensitivity	≤±1dB	Connector Pin	Beryllium Copper, Gold Plate
Directivity	≥10dB	Solder	Lead Free, RoHS Compliant
VSWR	Primary ≤1.50:1 Secondary ≤1.50:1	Operating Temperature	-55~+85°C
¹ Power Handling	Incident ≤10Watt; Reflected ≤10Watt	Operating Humidity	Up to 95%, Non- Condensing
Impedance	50Ω	Weight	90g
Port Connectors	SMA-Female		

¹Power Handling guaranteed when load's VSWR within 1.50:1.

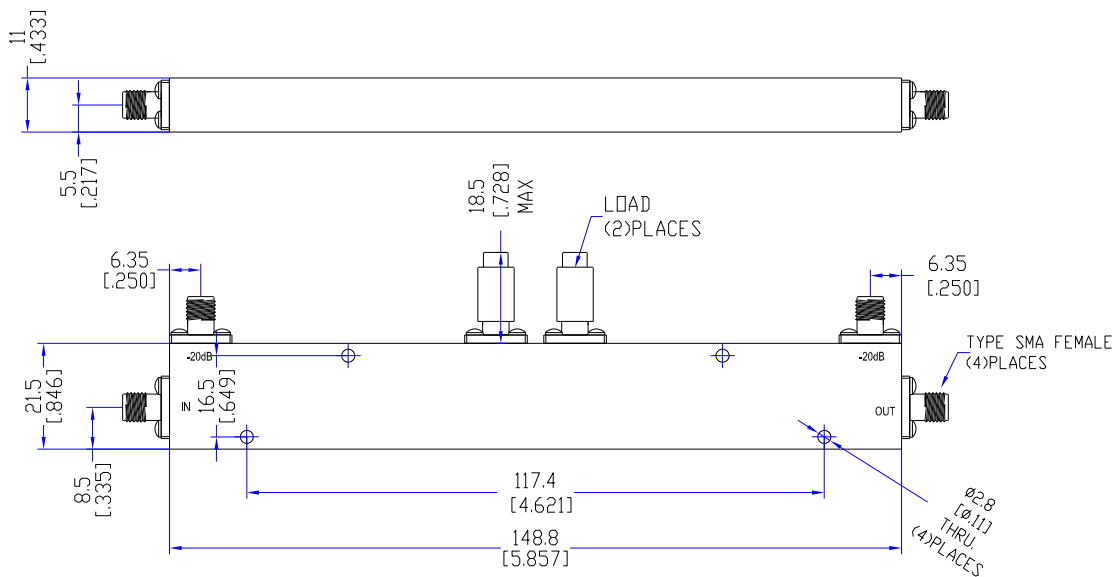

Typical Performance

1. Coupling Factor & Sensitivity, Isolation, VSWR

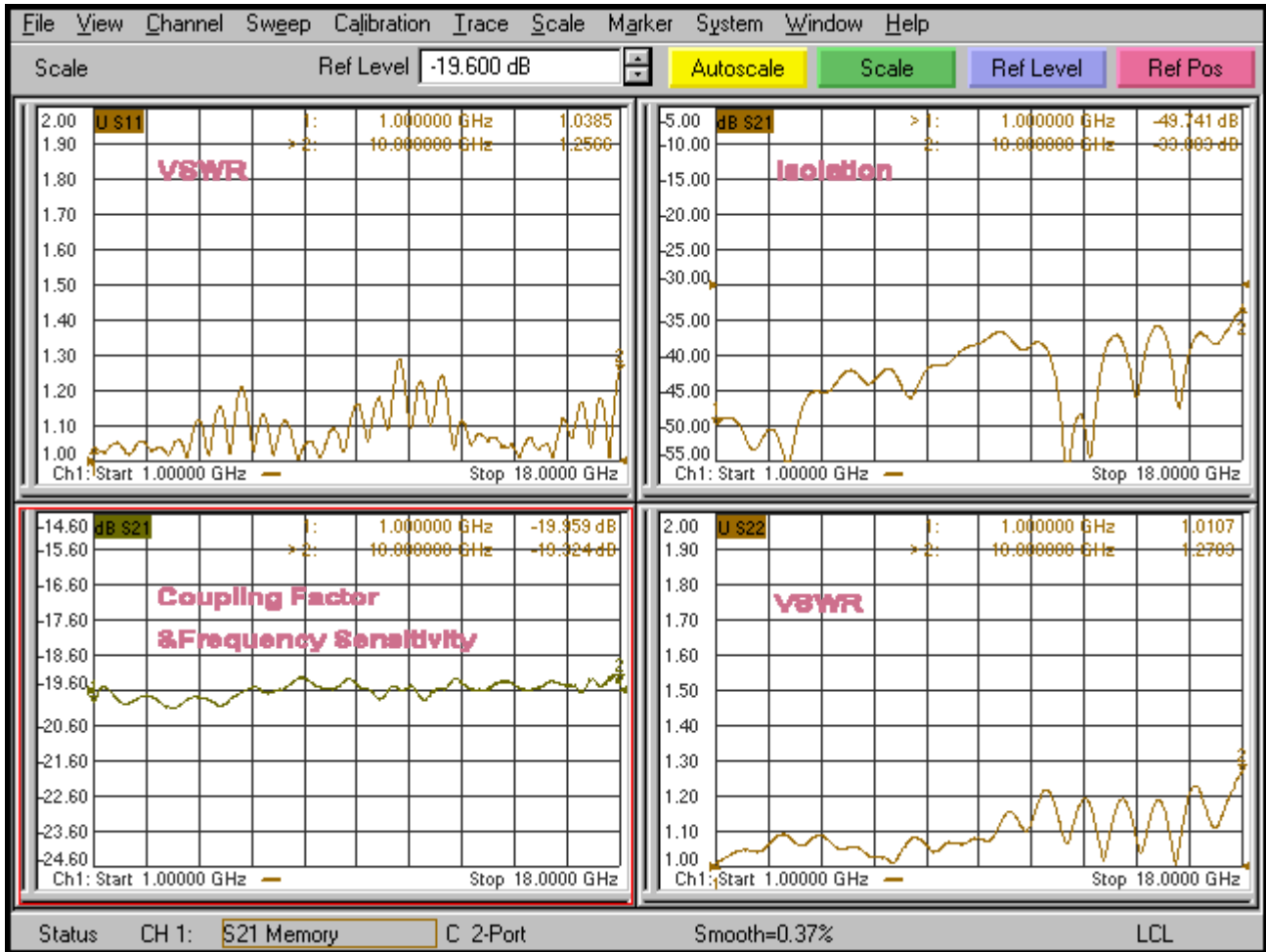

2. Insertion Loss

