

Model TDC460530A20

Features

Low VSWR
High Directivity
Broadband & Miniature Size

Technical Data Sheet			
Frequency Range	46~53GHz	Finish	Painted Blue_ RAL #5007
Insertion Loss	≤2.0dB (Excl. Coupling Loss 0.04dB)	Connector Body	Passivated Stainless Steel
Coupling Factor	≤20±1.0dB	Housing	Aluminum, 6061 T6 Clear Chem Conversion Film
Coupling Sensitivity	≤±1.5dB	Connector Pin	Beryllium Copper, Gold Plate
Directivity	≥6dB	Solder	Lead Free, RoHS Compliant
VSWR	Primary ≤1.70:1 Secondary ≤1.70:1	Operating Temperature	-55~+85°C
¹ Power Handling	Incident ≤20Watt; Reflected ≤1Watt	Operating Humidity	Up to 95%, Non- Condensing
Impedance	50Ω	Weight	30g
Port Connectors	1.85mm-Female		

¹Power Handling guaranteed when load's VSWR within 1.50:1.

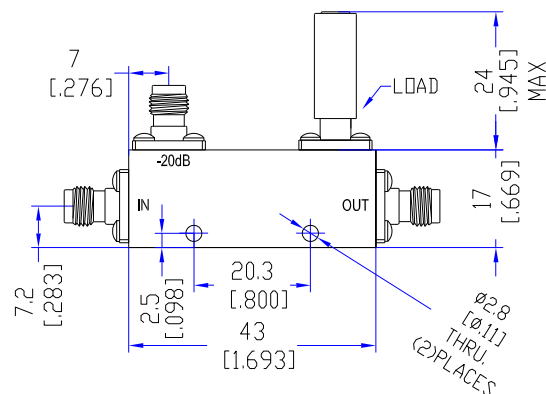
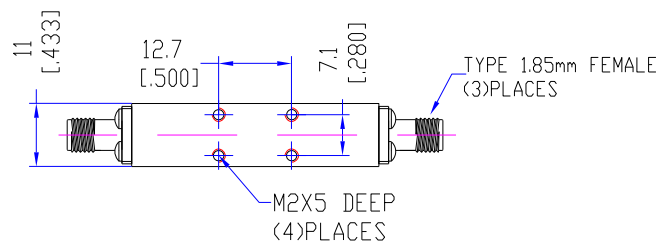

Typical Performance

1. Coupling Factor & Sensitivity, Isolation, VSWR

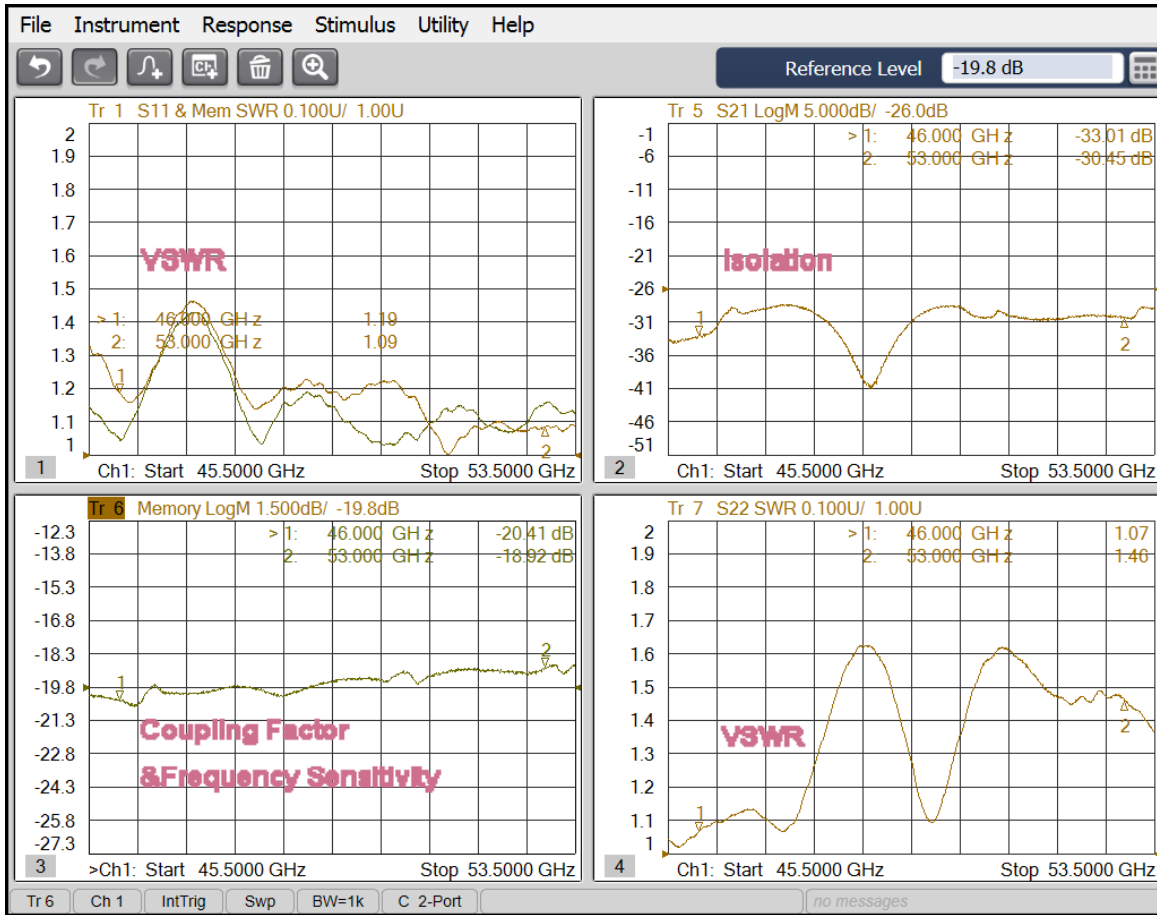

2. Insertion Loss

