

Model TPD0408A2B

Features

Excellent phase& amplitude balance
Low Insertion Loss& VSWR
High Isolation

Technical Data Sheet			
Frequency Range	400~800MHz	Finish	Natural Conductive Oxidation
Insertion Loss	≤0.4dB (Above 3.01dB Split)	Connector Body	Brass, Tri-Alloy Plate
VSWR	Input ≤1.30:1 Output ≤1.25:1	Housing	Aluminum, 6061 T6 Clear Chem Conversion Film
Isolation	≥20dB	Connector Pin	Beryllium Copper, Gold Plate
Amplitude Balance	≤±0.2dB	Solder	Lead Free, RoHS Compliant
Phase Balance	≤±2°	Operating Temperature	-55~+85°C
¹ Power Handling	Forward ≤30Watt; Reversed ≤1Watt	Operating Humidity	Up to 95%, Non- Condensing
Impedance	50Ω	Weight	80g
Port Connectors	BNC-Female		

¹Power Handling guaranteed when load's VSWR within 1.50:1.

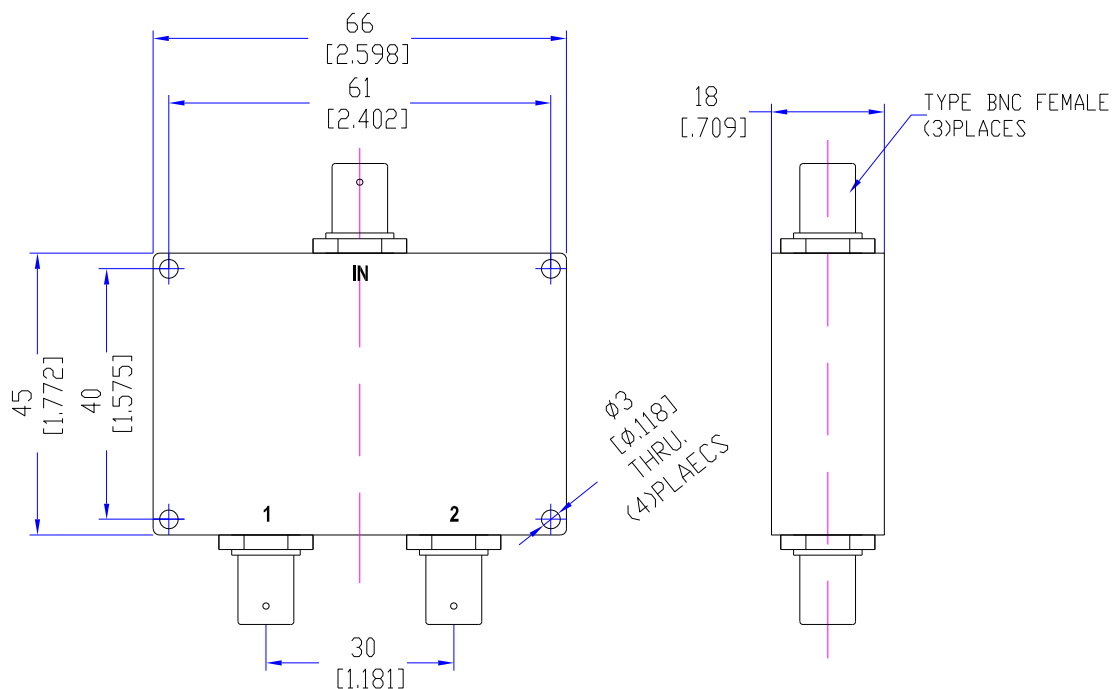

Typical Performance

1. Insertion Loss, Amplitude &Phase Balance, VSWR

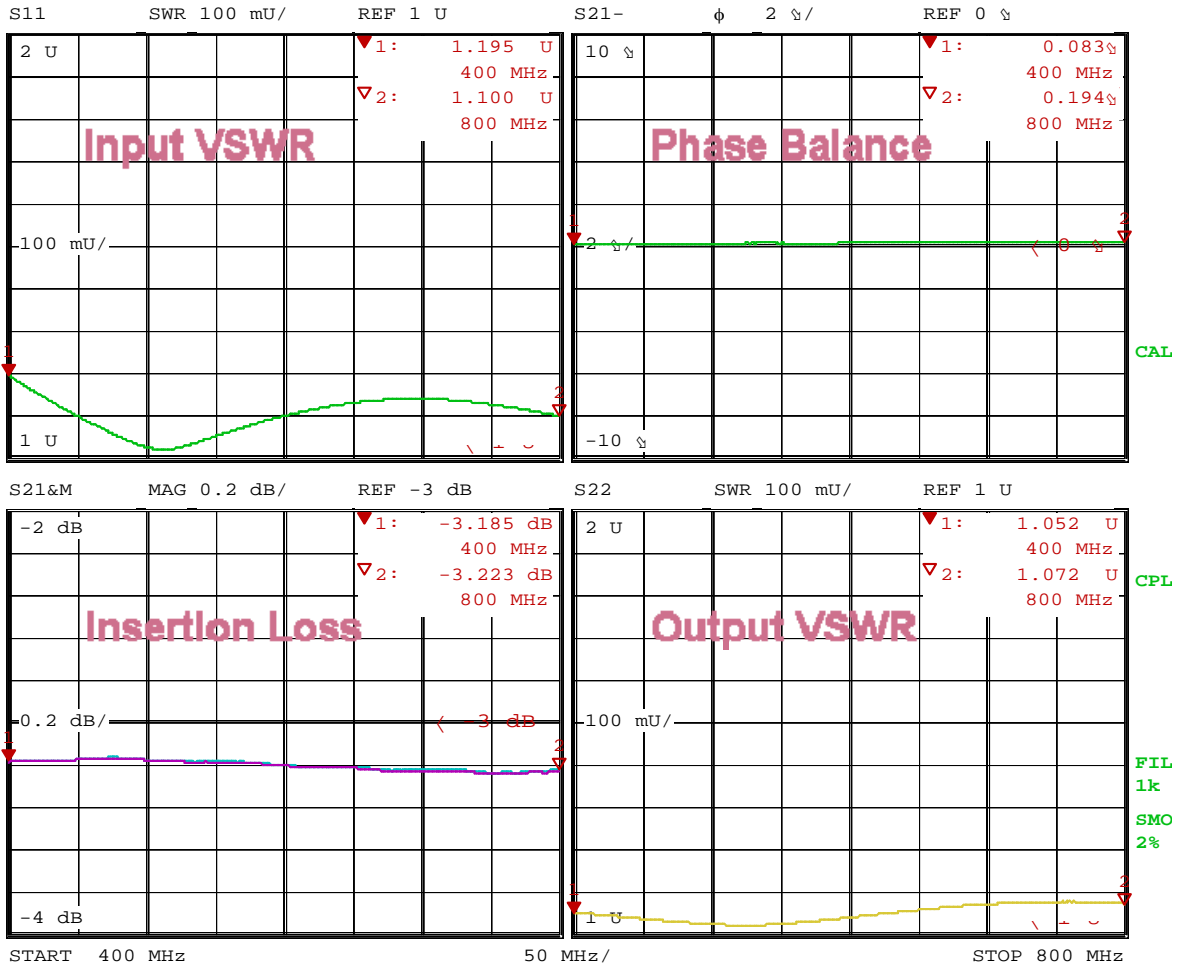

Date: 24.AUG.15 09:27:43

2. Isolation

