

Model TBF190818NB

Electrical Specifications

Pass Band Frequency	2405 -2505MHz
Insertion Loss	≤1.5dB
VSWR	≤1.30:1
Stop Band Rejection	≥50dB @ DC ~ 2280MHz ≥50dB @ 2630 ~ 5000MHz
Impedance	50 ohms
Power Handling	≤40W
Connectors	N-Male / N-Female
Finish	Painted Blue_ RAL #5007
Weight	250g

Environmental Parameters

Operating Temperature -20~+65°C

Operating Humidity Up to 90%,Non- Condensing

Outline Drawing

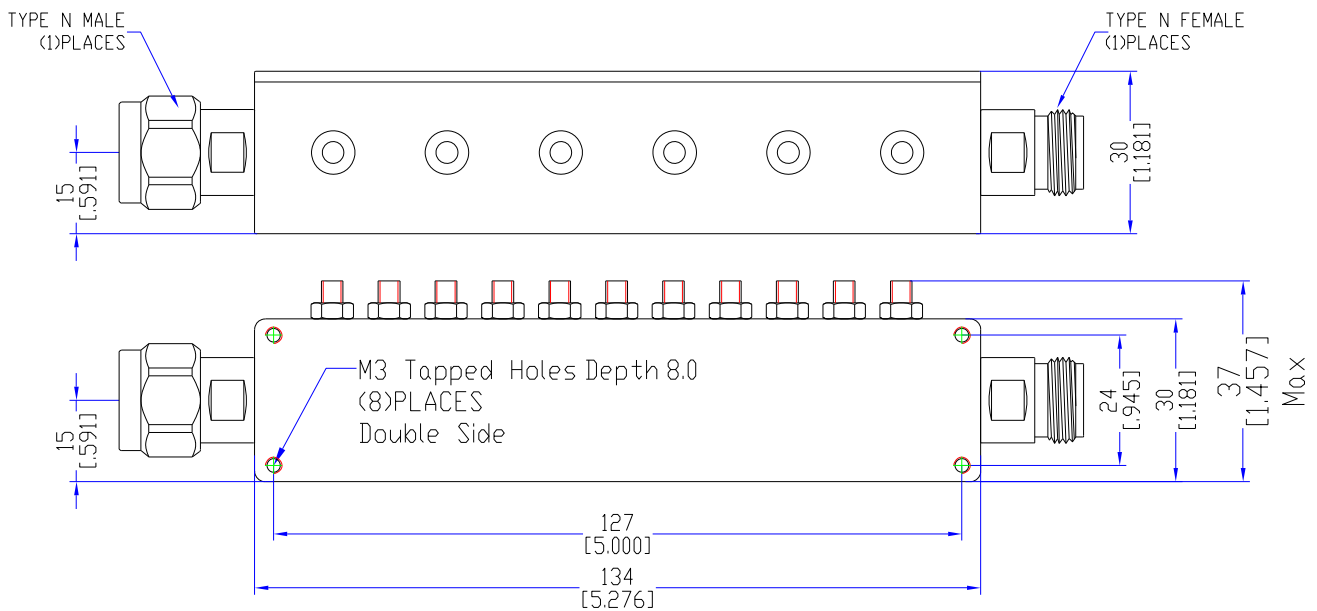

Typical Performance

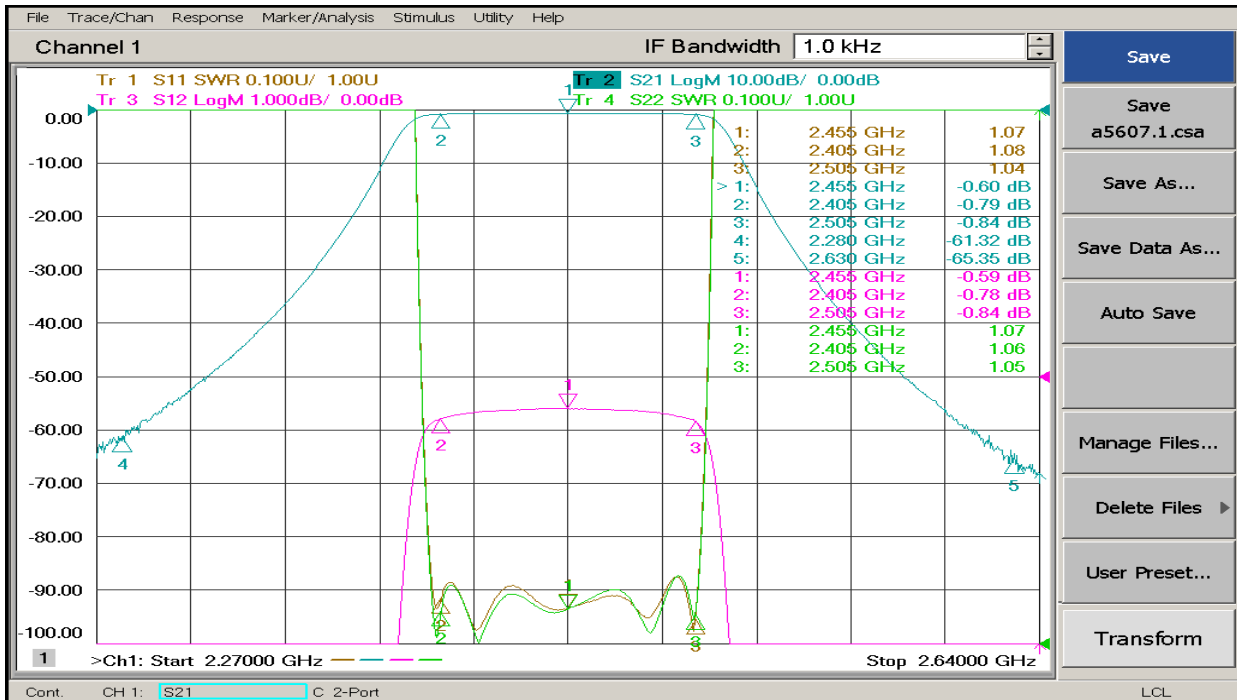

250

