

Model TBF190818NE

Electrical Specifications

Pass Band Frequency	5700-5900MHz
Insertion Loss	≤1.5dB
VSWR	≤1.30:1
Stop Band Rejection	≥50dB @ DC ~ 5530MHz ≥50dB @ 6070 ~ 12000MHz
Impedance	50 ohms
Power Handling	≤40W
Connectors	N-Male / N-Female
Finish	Painted Blue_ RAL #5007
Weight	140g

Environmental Parameters

Operating Temperature -20~+65°C

Operating Humidity Up to 90%,Non- Condensing

Outline Drawing

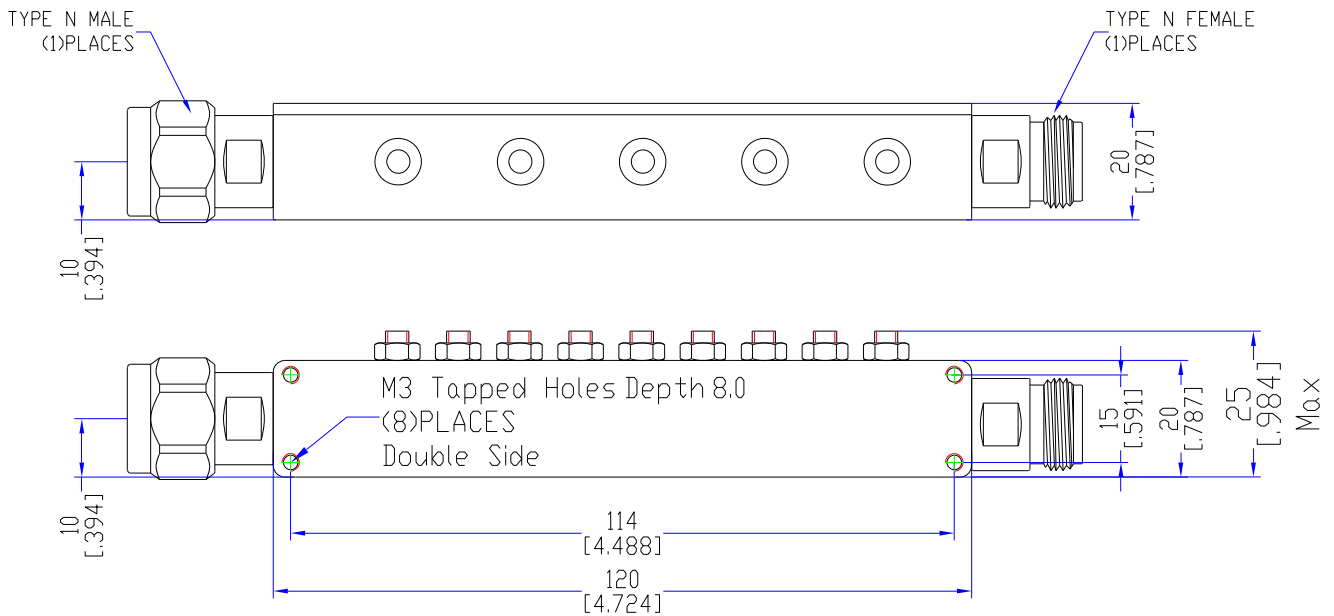

Typical Performance

