

Model TPD7185N2

Features

Excellent phase& amplitude balance
Low Insertion Loss& VSWR
High Isolation

Technical Data Sheet			
Frequency Range	7.1~8.5GHz	Finish	Painted Blue_ RAL #5007
Insertion Loss	≤0.7dB (Above 3.01dB Split)	Connector Body	Passivated Stainless Steel
VSWR	Input ≤1.30:1 Output ≤1.30:1	Housing	Aluminum, 6061 T6 Clear Chem Conversion Film
Isolation	≥20dB	Connector Pin	Beryllium Copper, Gold Plate
Amplitude Balance	≤±0.3dB	Solder	Lead Free, RoHS Compliant
Phase Balance	≤±3°	Operating Temperature	-40~+70°C
¹ Power Handling	Forward ≤30Watt; Reversed ≤1Watt	Operating Humidity	Up to 95%,Non- Condensing
Impedance	50Ω	Weight	150g
Port Connectors	N-Female		

¹Power Handling guaranteed when load's VSWR within 1.50:1.

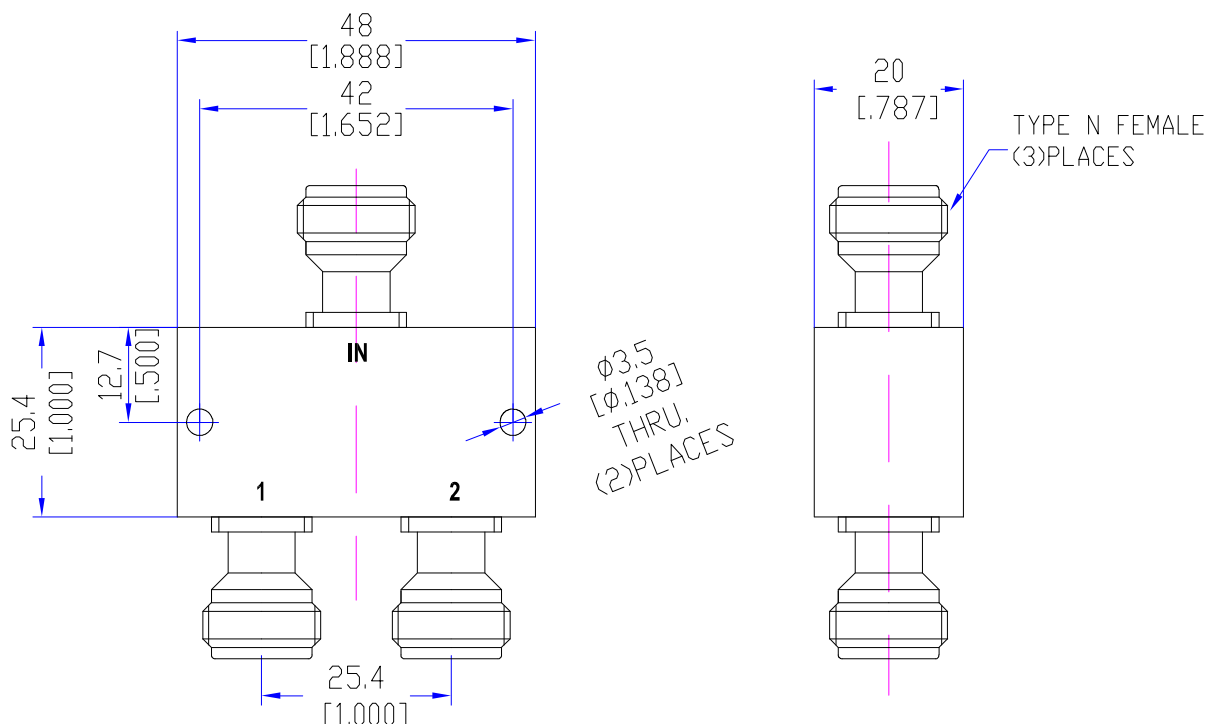

Typical Performance

1. Insertion Loss, Amplitude &Phase Balance, VSWR

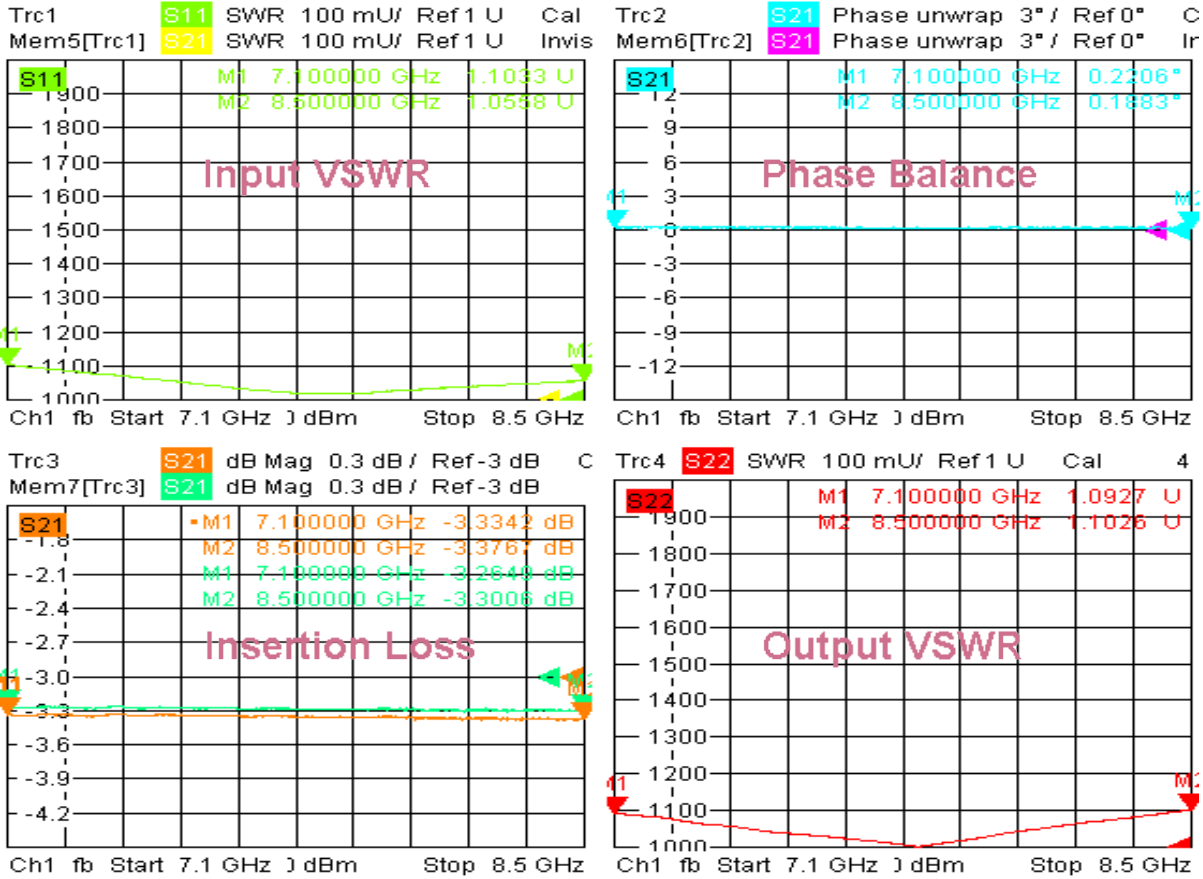

2. Isolation

