

Model TDC4452N20H

Features

Low VSWR
High Power
Broadband & Miniature Size

Technical Data Sheet			
Frequency Range	4.4~5.2GHz	Finish	Painted Blue_ RAL #5007
Insertion Loss	≤0.4dB (Excl. Coupling Loss 0.04dB)	Connector Body	Brass, Tri-Alloy Plate
Coupling Factor	≤20±0.7dB	Housing	Aluminum, 6061 T6 Clear Chem Conversion Film
Coupling Sensitivity	≤±0.7dB	Connector Pin	Beryllium Copper, Gold Plate
Directivity	≥18dB	Solder	Lead Free, RoHS Compliant
VSWR	Primary ≤1.30:1 Secondary ≤1.30:1	Operating Temperature	-40~+85°C
¹ Power Handling	Incident ≤100Watt; Reflected ≤5Watt	Operating Humidity	Up to 95%, Non- Condensing
Impedance	50Ω	Weight	160g
Port Connectors	N-Female		

¹Power Handling guaranteed when load's VSWR within 1.50:1.

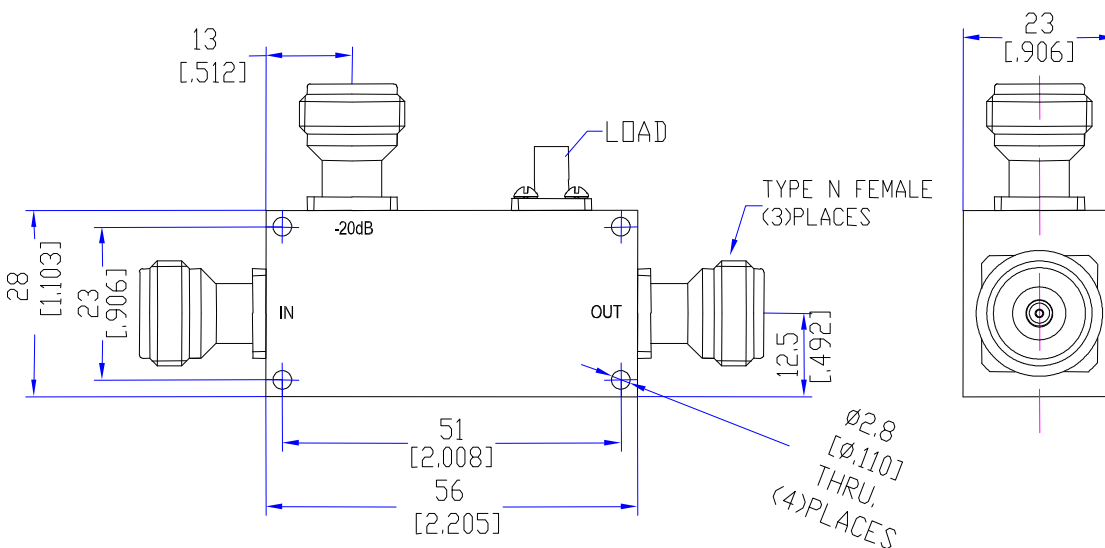

Typical Performance

1. Coupling Factor & Sensitivity, Isolation, VSWR

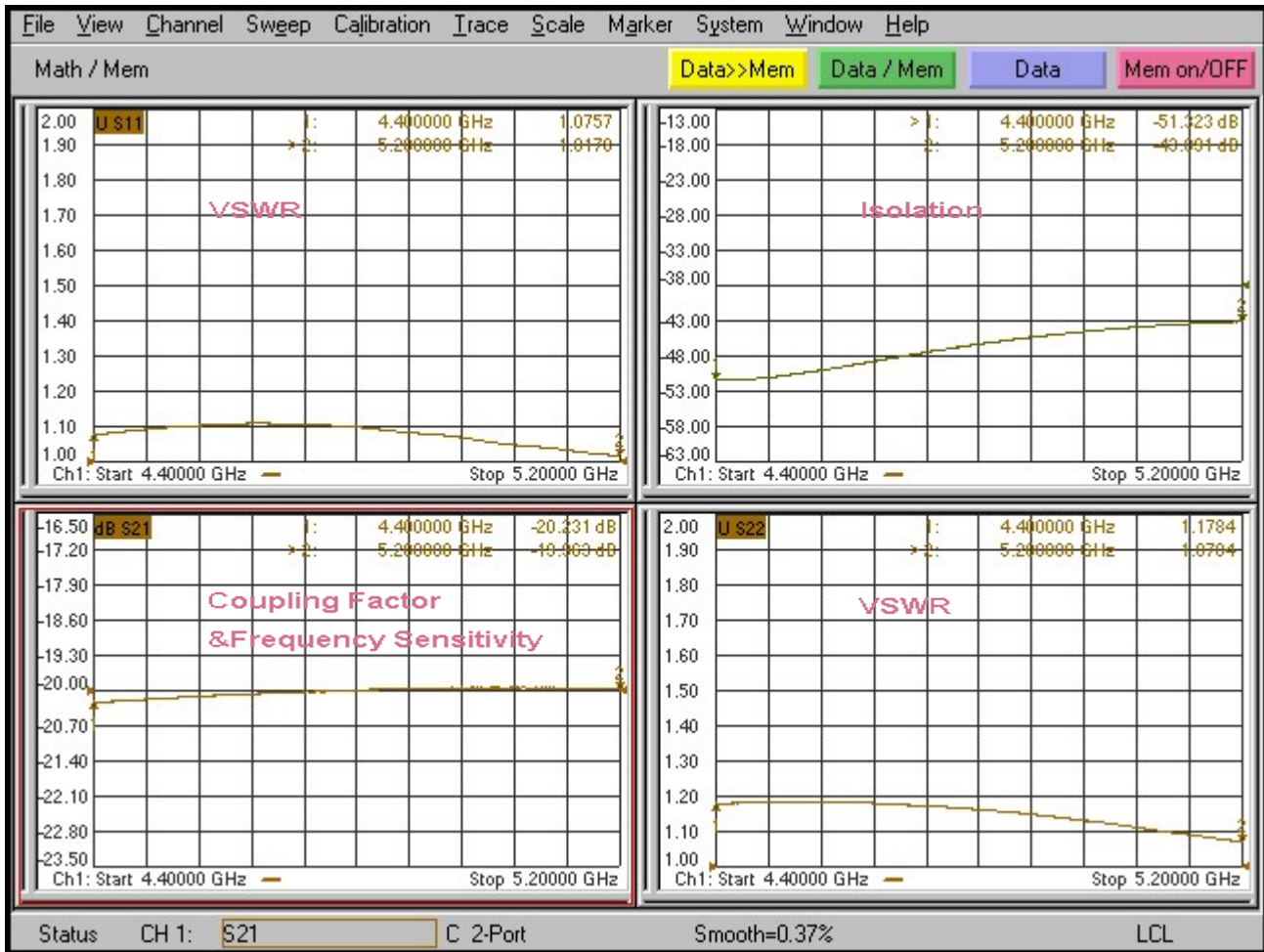

2. Insertion Loss

