

Model TDC5759N30H

Features

Low VSWR
High Directivity
Broadband & Miniature Size

Technical Data Sheet			
Frequency Range	5.7~5.9GHz	Finish	Painted Blue_ RAL #5007
Insertion Loss	≤0.4dB (Excl. Coupling Loss 0.01dB)	Connector Body	Passivated Stainless Steel
Coupling Factor	≤30±1dB	Housing	Aluminum, 6061 T6 Clear Chem Conversion Film
Coupling Sensitivity	≤±0.8dB	Connector Pin	Beryllium Copper, Gold Plate
Directivity	≥24dB	Solder	Lead Free, RoHS Compliant
VSWR	Primary ≤1.30:1 Secondary ≤1.30:1	Operating Temperature	-20~+65°C
¹ Power Handling	Incident ≤150Watt; Reflected ≤50Watt	Operating Humidity	Up to 95%, Non- Condensing
Impedance	50Ω	Weight	160g
Port Connectors	N-Female		

¹Power Handling guaranteed when load's VSWR within 1.50:1.

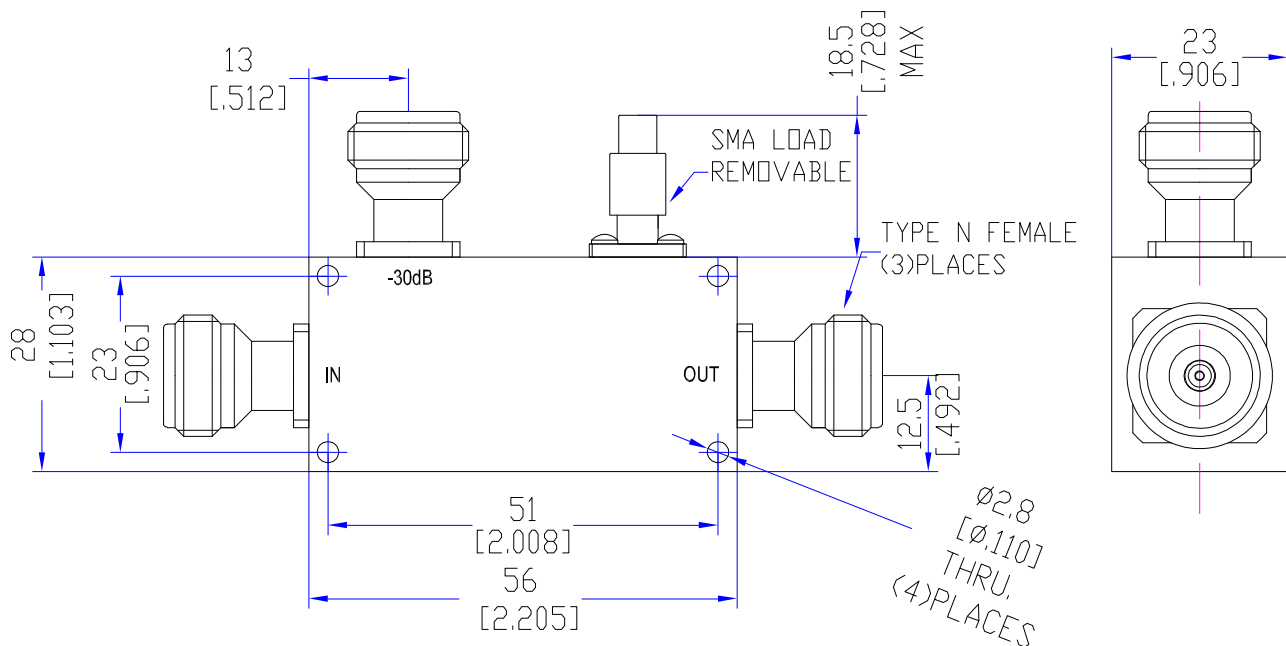

Typical Performance

1. Coupling Factor & Sensitivity, Isolation, VSWR

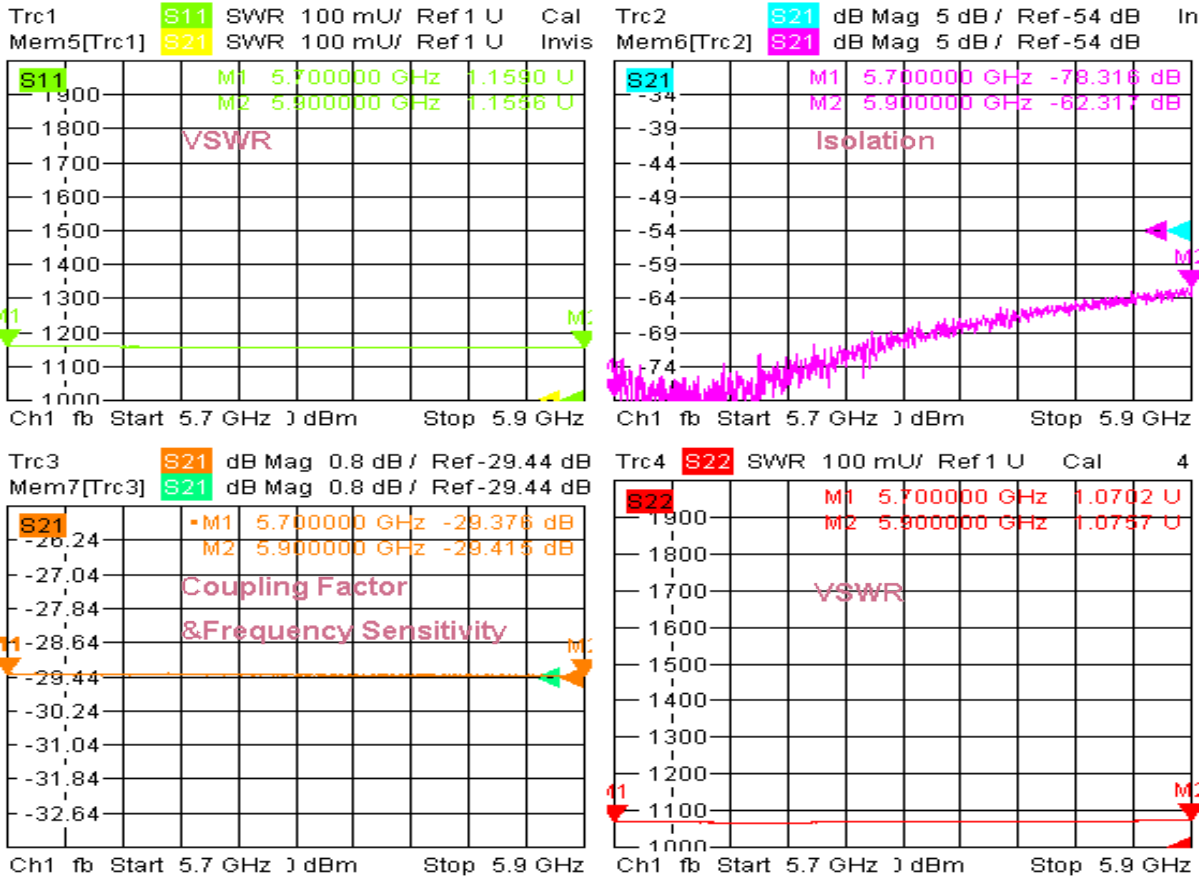

10/21/2019, 3:05 AM

2. Insertion Loss

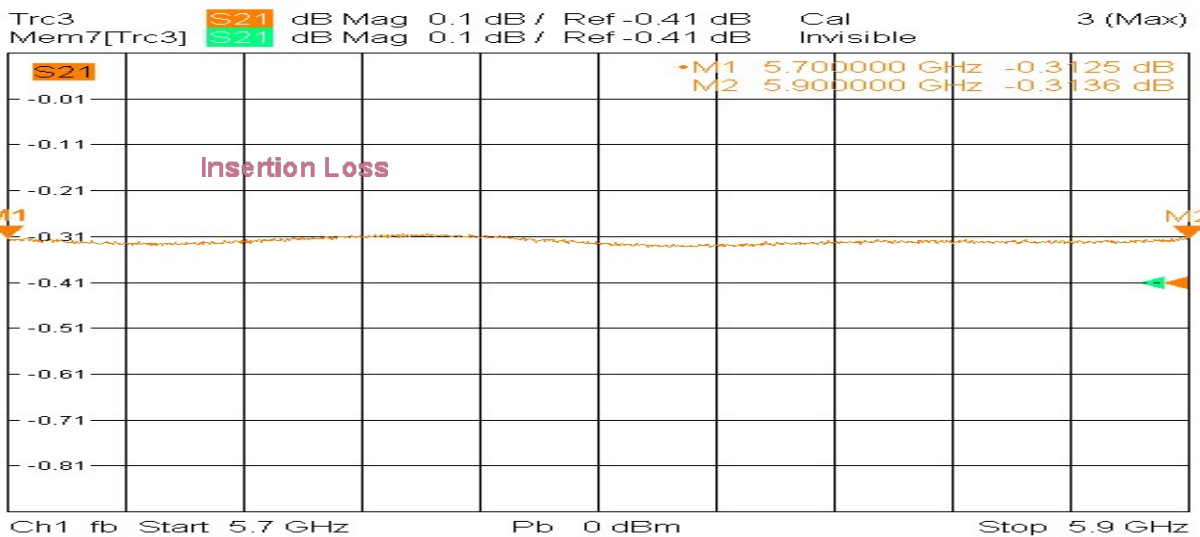

160 10/21/2019, 3:11 AM

