

Model TPD120180N2

Features

- Excellent phase& amplitude balance
- Low Insertion Loss& VSWR
- High Isolation

Technical Data Sheet			
Frequency Range	12~18GHz	Finish	Painted Blue_ RAL #5007
Insertion Loss	≤1.0dB (Above 3.01dB Split)	Connector Body	Brass, Tri-Alloy Plate
VSWR	Input ≤1.50:1 Output ≤1.50:1	Housing	Aluminum, 6061 T6 Clear Chem Conversion Film
Isolation	≥18dB	Connector Pin	Beryllium Copper, Gold Plate
Amplitude Balance	≤±0.3dB	Solder	Lead Free, RoHS Compliant
Phase Balance	≤±3°	Operating Temperature	-55~+85°C
¹ Power Handling	Forward ≤20Watt; Rev. ≤1Watt each port	Operating Humidity	Up to 95%,Non- Condensing
Impedance	50Ω	Weight	150g
Port Connectors	N-Female		

¹Power Handling guaranteed when load's VSWR within 1.50:1.

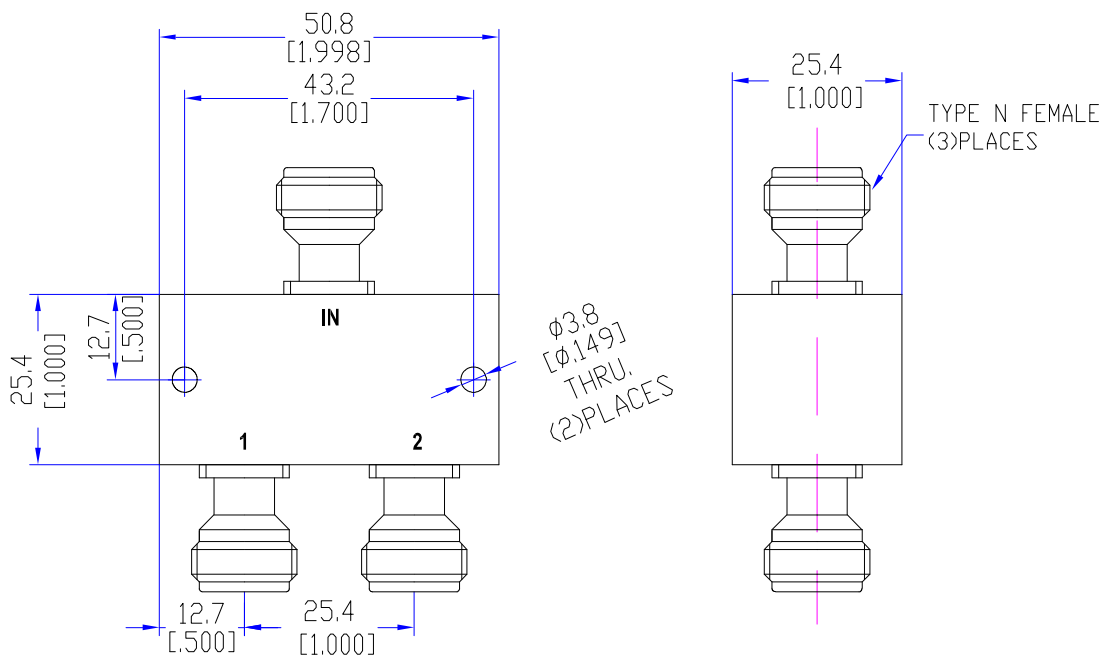

Typical Performance

1. Insertion Loss, Amplitude &Phase Balance, VSWR

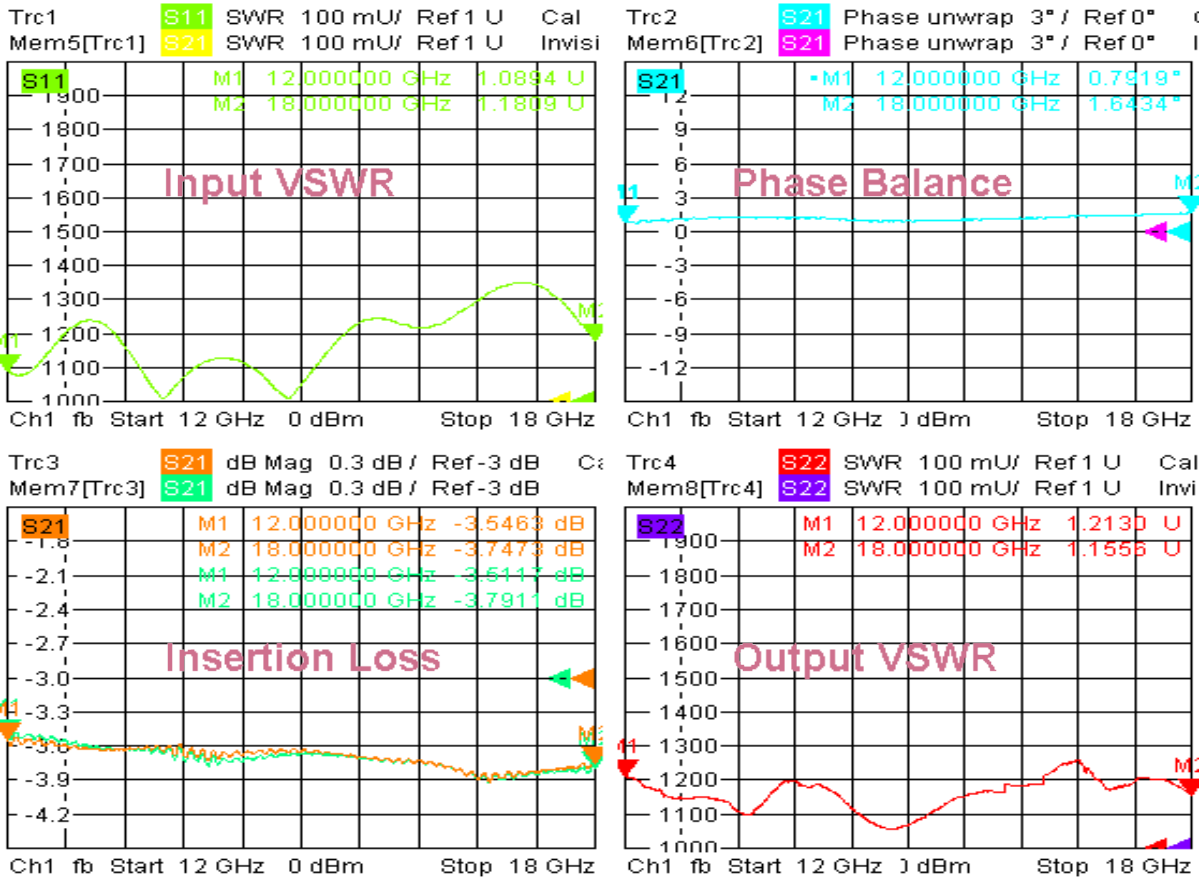

10/15/2018, 2:51 PM

2. Isolation

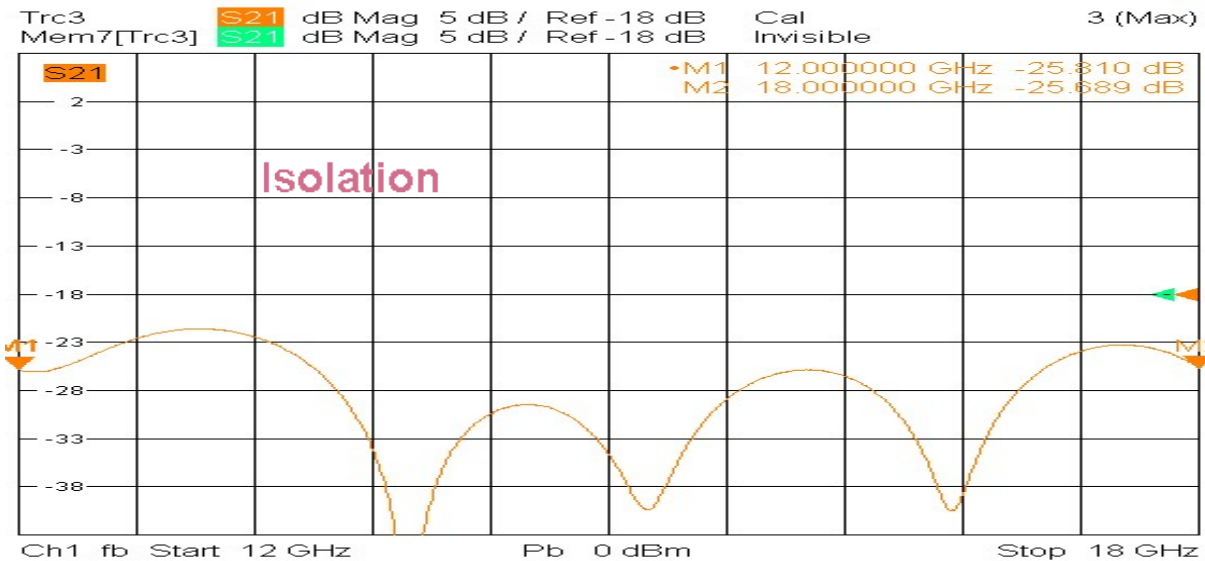

10/15/2018, 2:53 PM

