

## Model THC94105U

### Features

Excellent phase& amplitude balance  
Low Insertion Loss& VSWR  
High Isolation

Technical Data Sheet			
Frequency Range	9.4~10.5GHz	Finish	Painted Blue_ RAL #5007
Nominal Split	6.02dB	Connector Body	Passivated Stainless Steel
Insertion Loss	≤1.8dB	Housing	Aluminum, 6061 T6
Isolation	≥20dB		Clear Chem Conversion Film
Amplitude Balance	≤±0.5dB	Connector Pin	Beryllium Copper, Gold Plate
Phase Balance	≤±5°	Solder	Lead Free, RoHS Compliant
VSWR	≤1.50:1	Operating Temperature	-55~+85°C
<sup>1</sup> Power Handling	Average ≤10Watt Peak ≤0.1KW	Operating Humidity	Up to 95%,Non- Condensing
Impedance	50Ω	Weight	110g
Port Connectors	SMA-Female		

<sup>1</sup>Power Handling guaranteed when load's VSWR within 1.50:1.

### Phase Relationship

A to ELΔ	A to AZΣ	A to ΔQ	A to AZΔ
0°	90°	180°	270°
D to ELΔ	D to AZΣ	D to ΔQ	D to AZΔ
0°	-90°	-180°	-270°

### Environmental Parameters

Operating Temperature -55~+85°C

Operating Humidity Up to 90%,Non- Condensing



Schematic

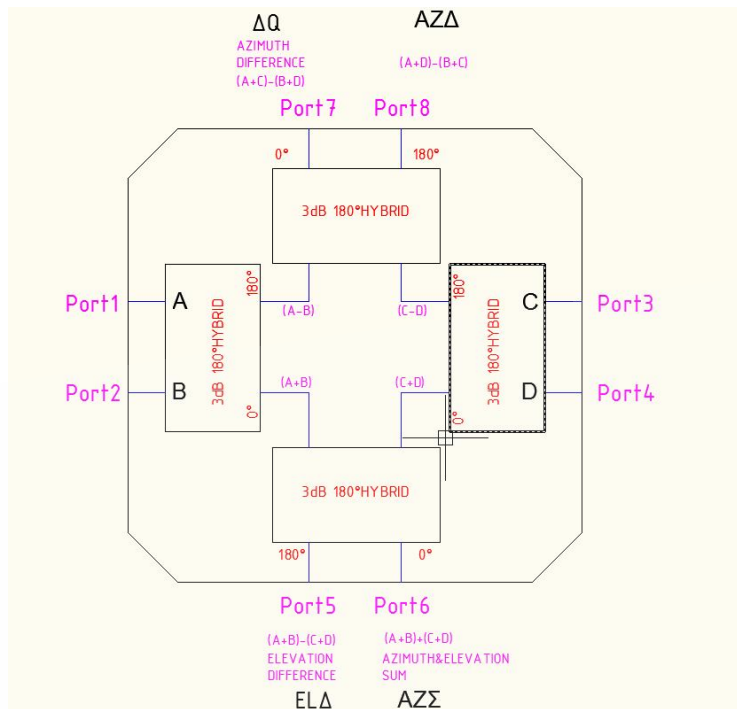

Outline Drawing

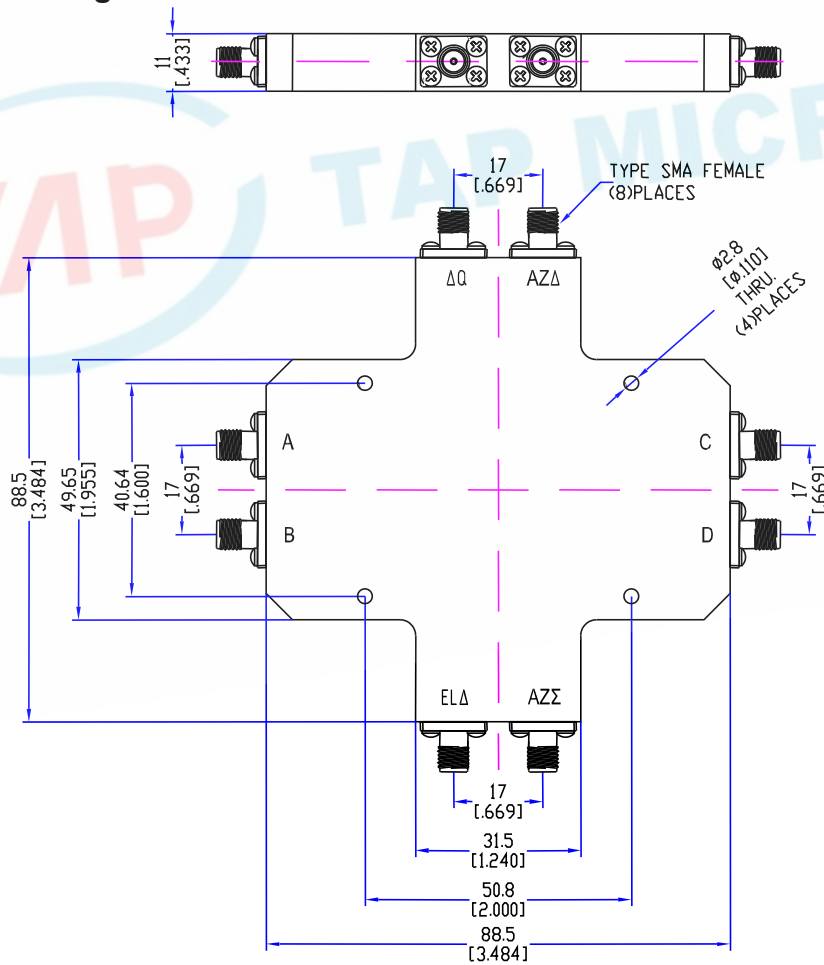

## Typical Performance

### 1. 1. Insertion Loss, Amplitude & Phase Balance, VSWR



Trc1 Mem5[Trc1] S11 SWR 100 mU/ Ref 1 U Cal  
S11 SWR 100 mU/ Ref 1 U Invisib

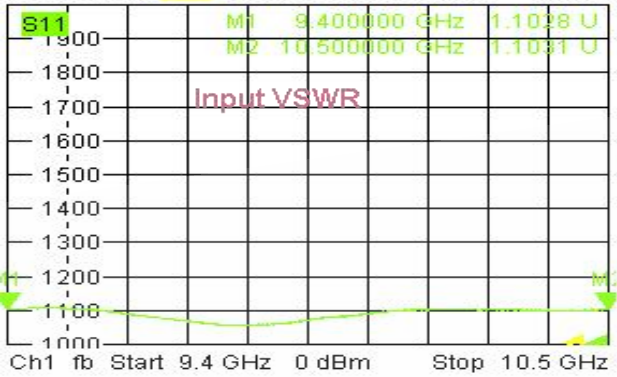

Trc2 Mem6[Trc2] S21 Phase unwrap 5° / Ref 90°  
S21 Phase unwrap 5° / Ref 90°

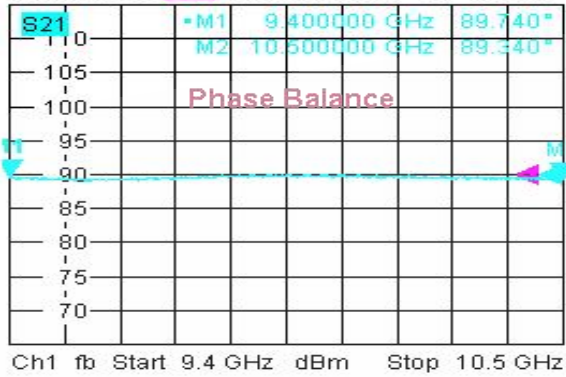

Trc3 Mem7[Trc3] S21 dB Mag 0.5 dB / Ref -6 dB Cal  
S21 dB Mag 0.5 dB / Ref -6 dB

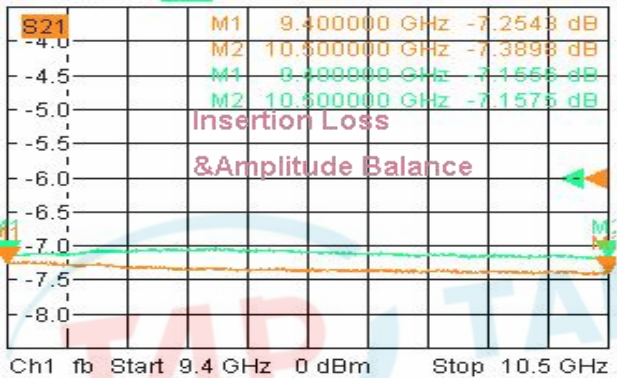

Trc4 Mem8[Trc4] S22 SWR 100 mU/ Ref 1 U Ca  
S22 SWR 100 mU/ Ref 1 U Inv

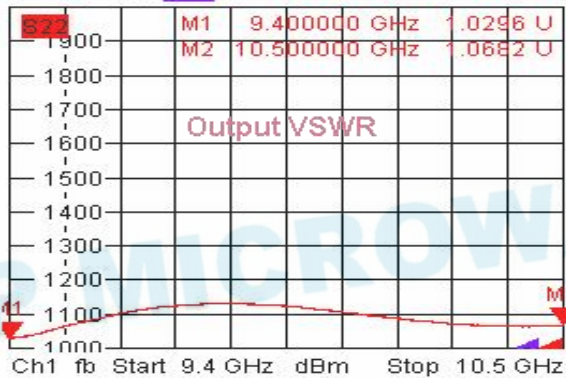

7/9/2020, 10:32 AM



## Typical Performance

### 2. Insertion Loss, Amplitude & Phase Balance, VSWR

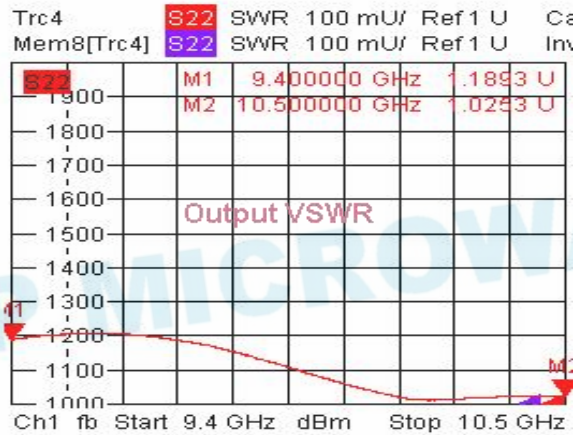
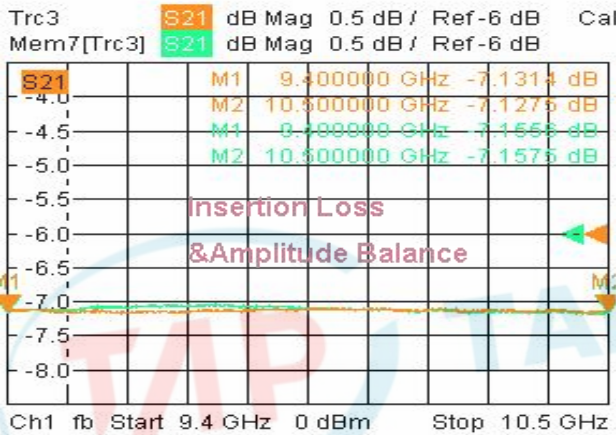
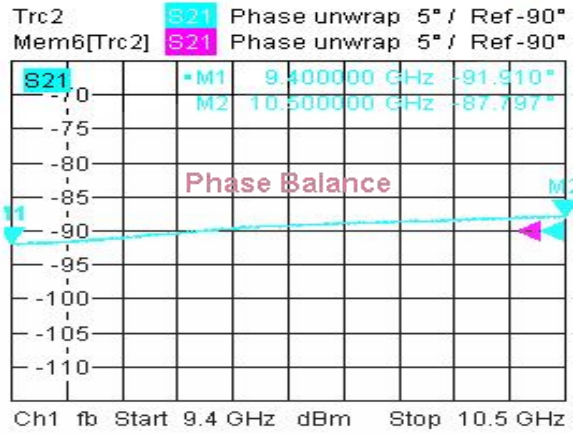
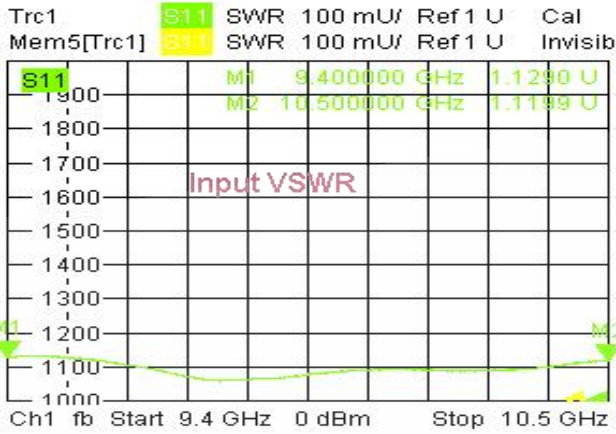

7/9/2020, 10:33 AM



### Typical Performance

3.Insertion Loss, Amplitude & Phase Balance, VSWR\_ 0°

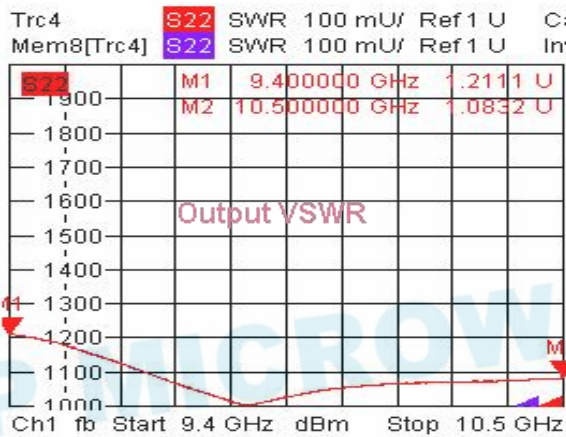
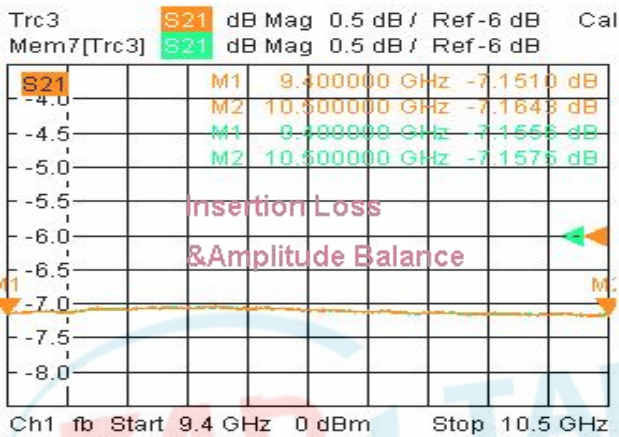
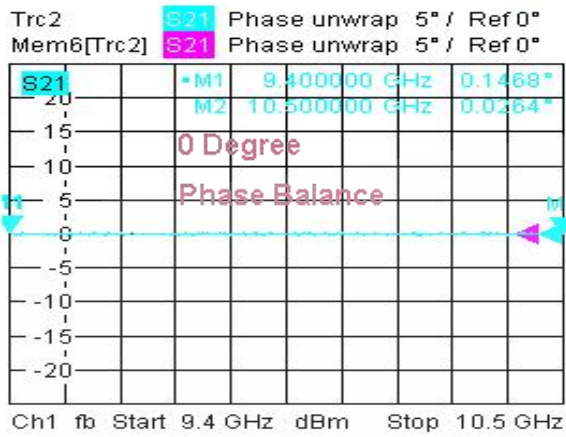
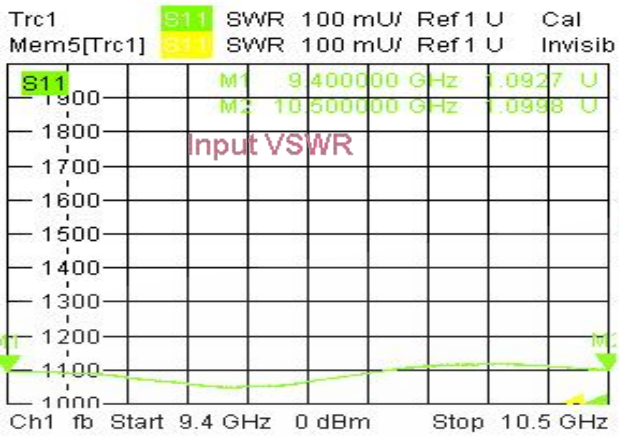

7/9/2020, 10:32 AM



### Typical Performance

#### 4. Insertion Loss, Amplitude & Phase Balance, VSWR \_ 180°

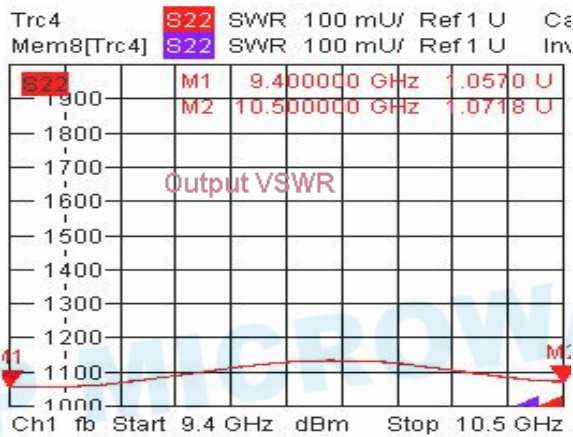
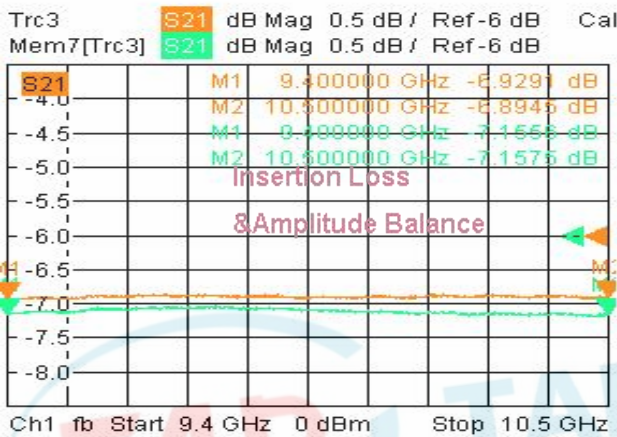
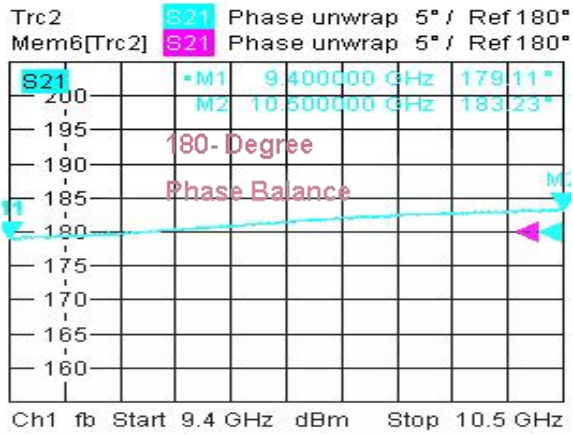
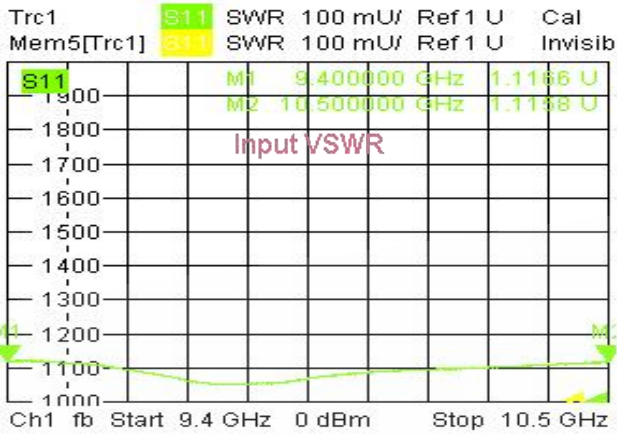

7/9/2020, 10:33 AM

#### 5. Isolation

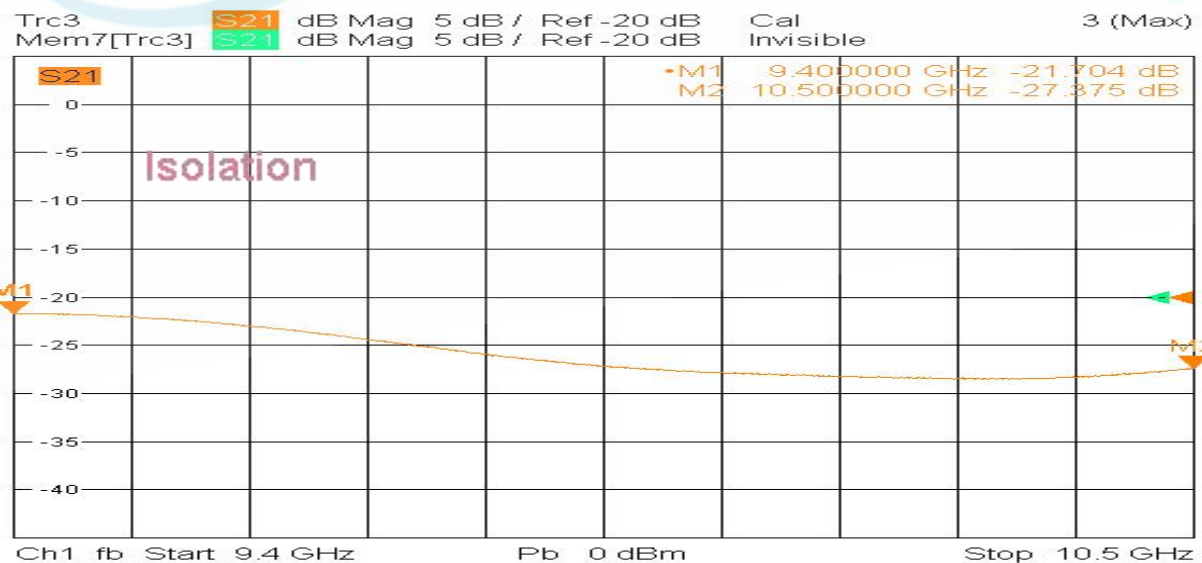

7/9/2020, 10:37 AM

