

Model TPD120180A4

Features

- Excellent phase & amplitude balance
- Low Insertion Loss & VSWR
- High Isolation

Technical Data Sheet			
Frequency Range	12~18GHz	Finish	Painted Blue_ RAL #5007
Insertion Loss	≤1.1dB (Above 6.02dB Split)	Connector Body	Passivated Stainless Steel
VSWR	Input ≤1.40:1 Output ≤1.30:1	Housing	Aluminum, 6061 T6 Clear Chem Conversion Film
Isolation	≥18dB	Connector Pin	Beryllium Copper, Gold Plate
Amplitude Balance	≤±0.5dB	Solder	Lead Free, RoHS Compliant
Phase Balance	≤±5°	Operating Temperature	-55~+85°C
¹ Power Handling	Forward ≤20Watt; Reversed ≤1Watt	Operating Humidity	Up to 95%, Non-Condensing
Impedance	50Ω	Weight	50g
Port Connectors	SMA-Female		

¹Power Handling guaranteed when load's VSWR within 1.50:1.

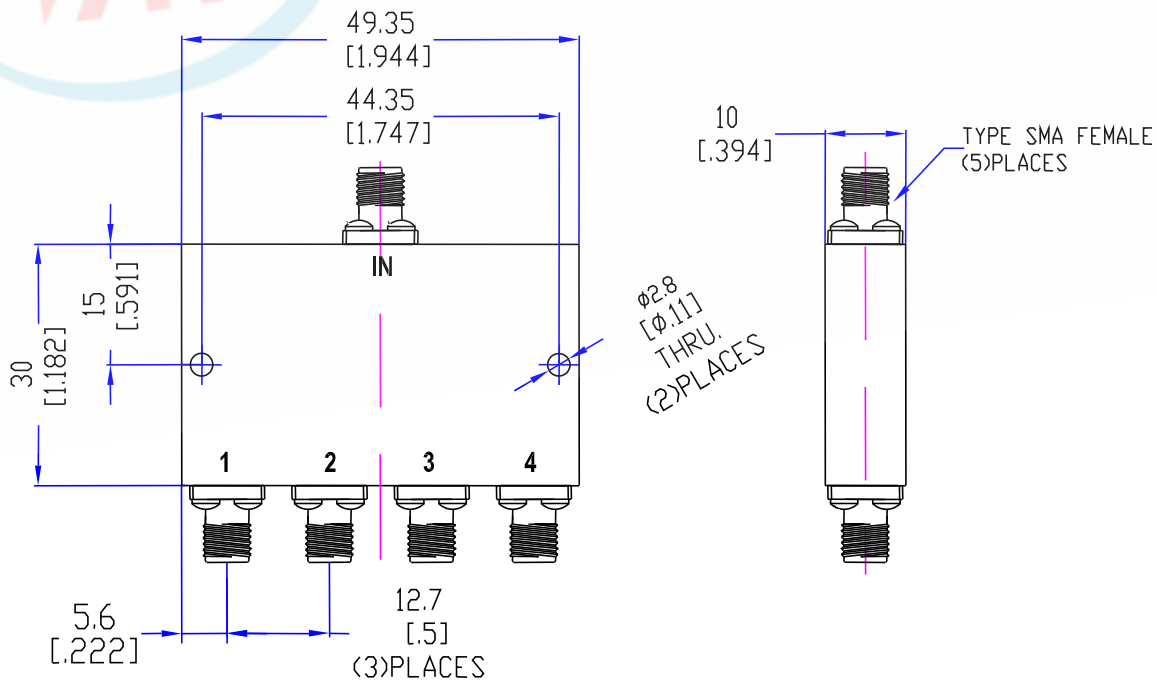

Typical Performance

1. Insertion Loss, Amplitude & Phase Balance, VSWR

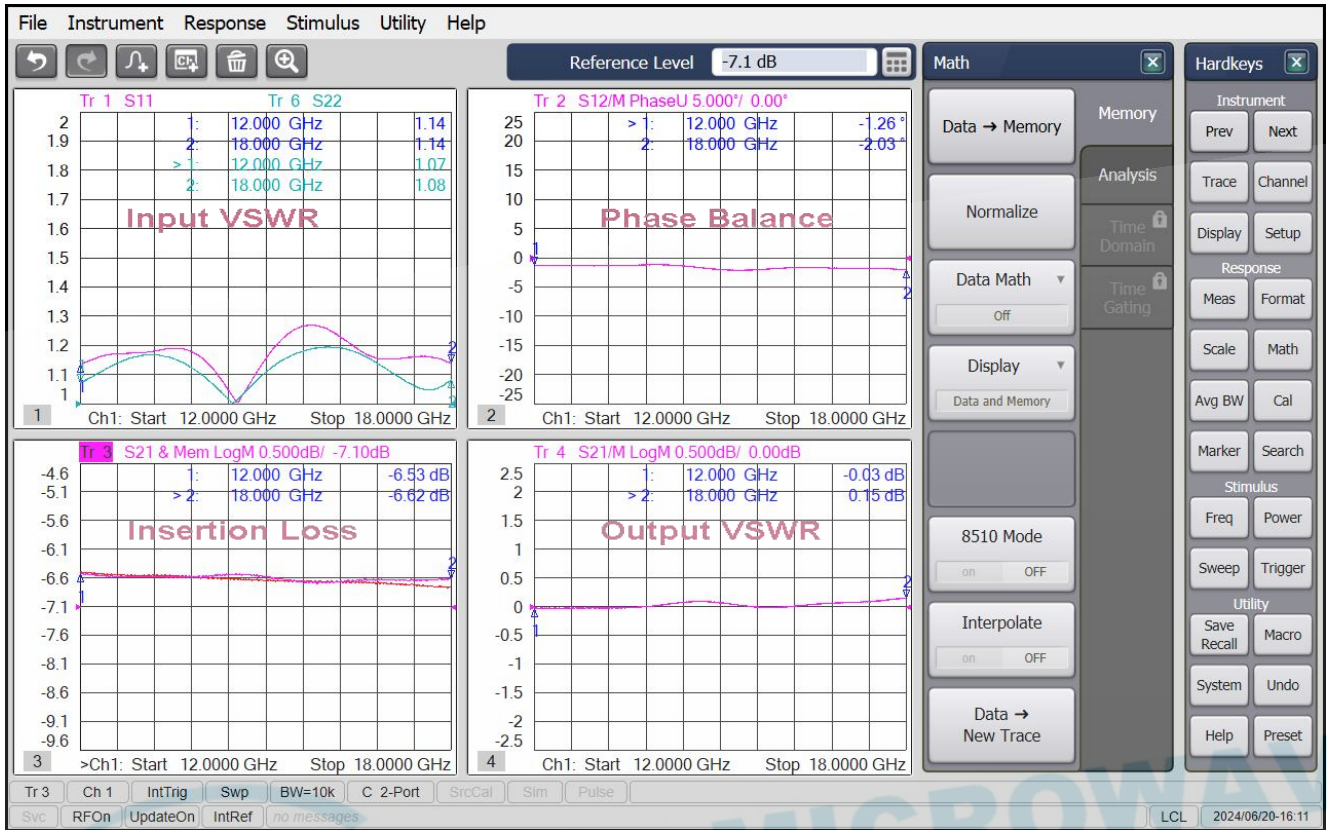

2. Isolation

