

Model TPD180500A4F

Features

- Excellent phase & amplitude balance
- Low Insertion Loss & VSWR
- High Isolation

Technical Data Sheet			
Frequency Range	18~50GHz	Finish	Painted Blue_ RAL #5007
Insertion Loss	≤2.6dB (Above 6.02dB Split)	Connector Body	Passivated Stainless Steel
VSWR	Input ≤1.80:1 Output ≤1.80:1	Housing	Aluminum, 6061 T6 Clear Chem Conversion Film
Isolation	≥15dB	Connector Pin	Beryllium Copper, Gold Plate
Amplitude Balance	≤±0.6dB	Solder	Lead Free, RoHS Compliant
Phase Balance	≤±8°	Operating Temperature	-55~+85°C
¹ Power Handling	Forward ≤10Watt; Reversed ≤0.5Watt	Operating Humidity	Up to 95%, Non-Condensing
Impedance	50Ω	Weight	40g
Port Connectors	2.4mm-Female		

¹Power Handling guaranteed when load's VSWR within 1.50:1.

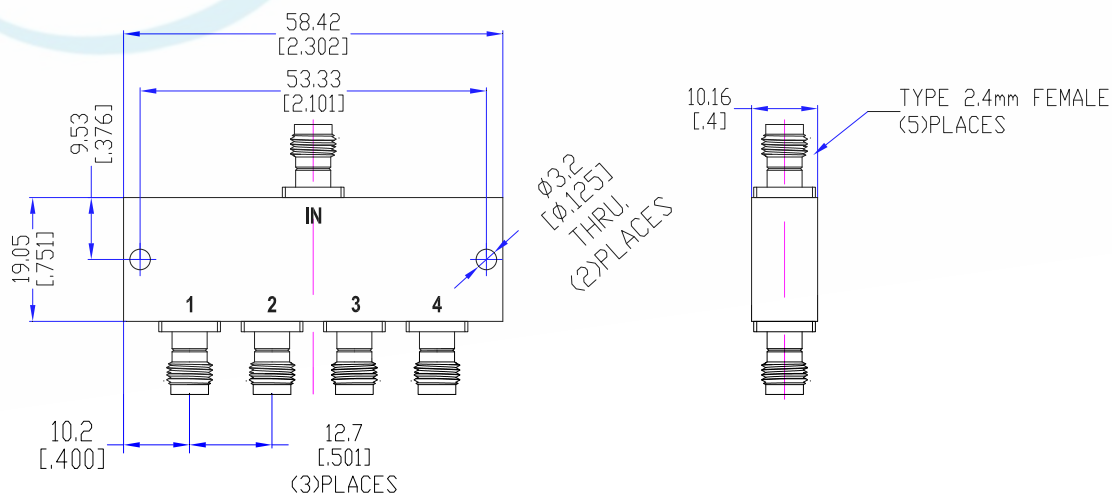

Typical Performance

1. Insertion Loss, Amplitude & Phase Balance, VSWR

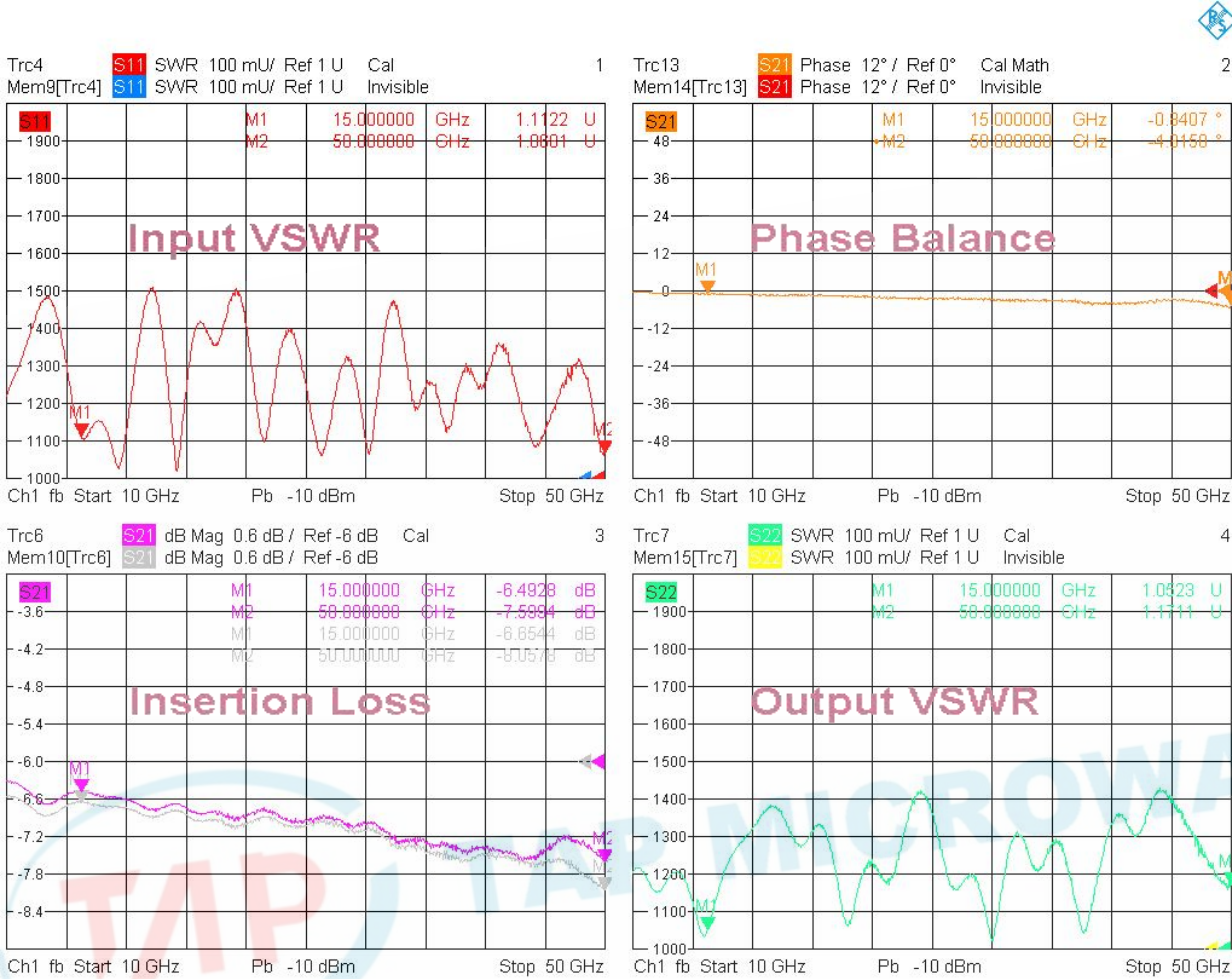

5/23/2024, 3:10 PM

2. Insertion Loss

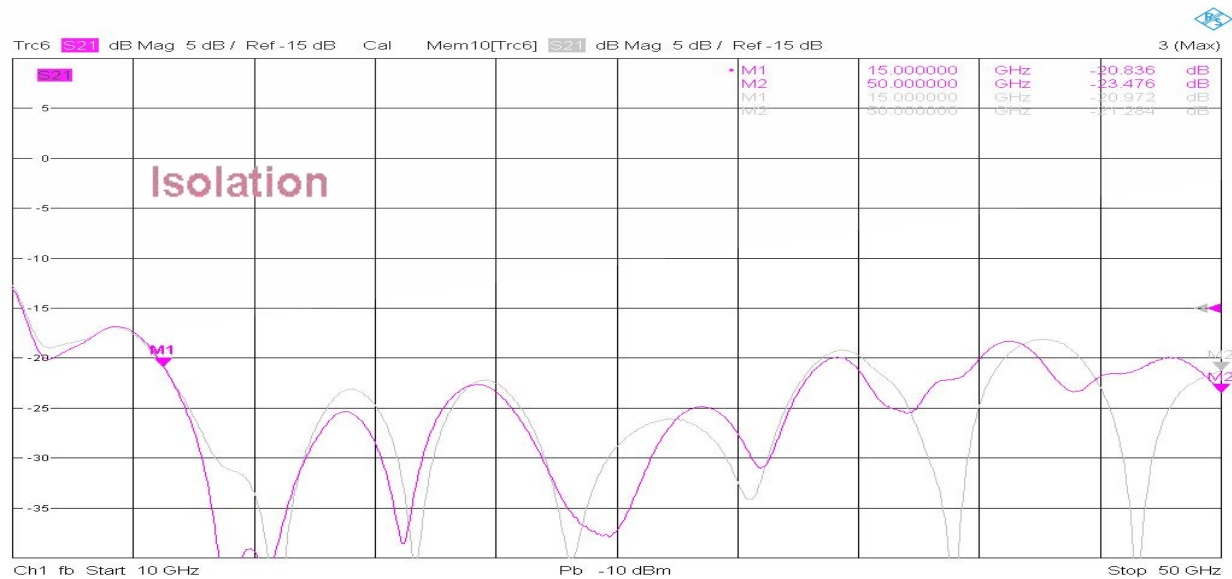

5/23/2024, 2:58 PM

