

## Model TPD370500A4

### Features

- Excellent phase& amplitude balance
- Low Insertion Loss& VSWR
- High Isolation

Technical Data Sheet			
Frequency Range	37~50GHz	Finish	Painted Blue_ RAL #5007
Insertion Loss	≤2.6dB (Above 6.02dB Split)	Connector Body	Passivated Stainless Steel
VSWR	Input ≤1.70:1 Output ≤1.70:1	Housing	Aluminum, 6061 T6 Clear Chem Conversion Film
Isolation	≥15dB	Connector Pin	Beryllium Copper, Gold Plate
Amplitude Balance	≤±0.6dB	Solder	Lead Free, RoHS Compliant
Phase Balance	≤±8°	Operating Temperature	-55~+85°C
<sup>1</sup> Power Handling	Forward ≤10Watt; Reversed ≤0.5Watt	Operating Humidity	Up to 95%, Non- Condensing
Impedance	50Ω	Weight	50g
Port Connectors	2.4mm-Female		

<sup>1</sup>Power Handling guaranteed when load's VSWR within 1.50:1.

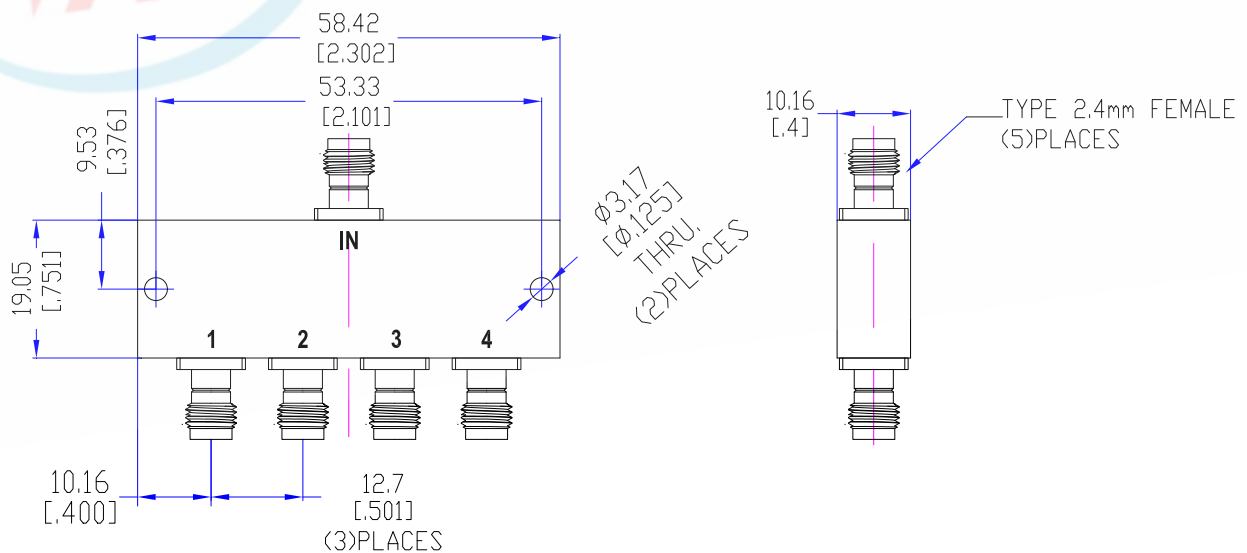

## Typical Performance

### 1. Insertion Loss, Amplitude &Phase Balance, VSWR

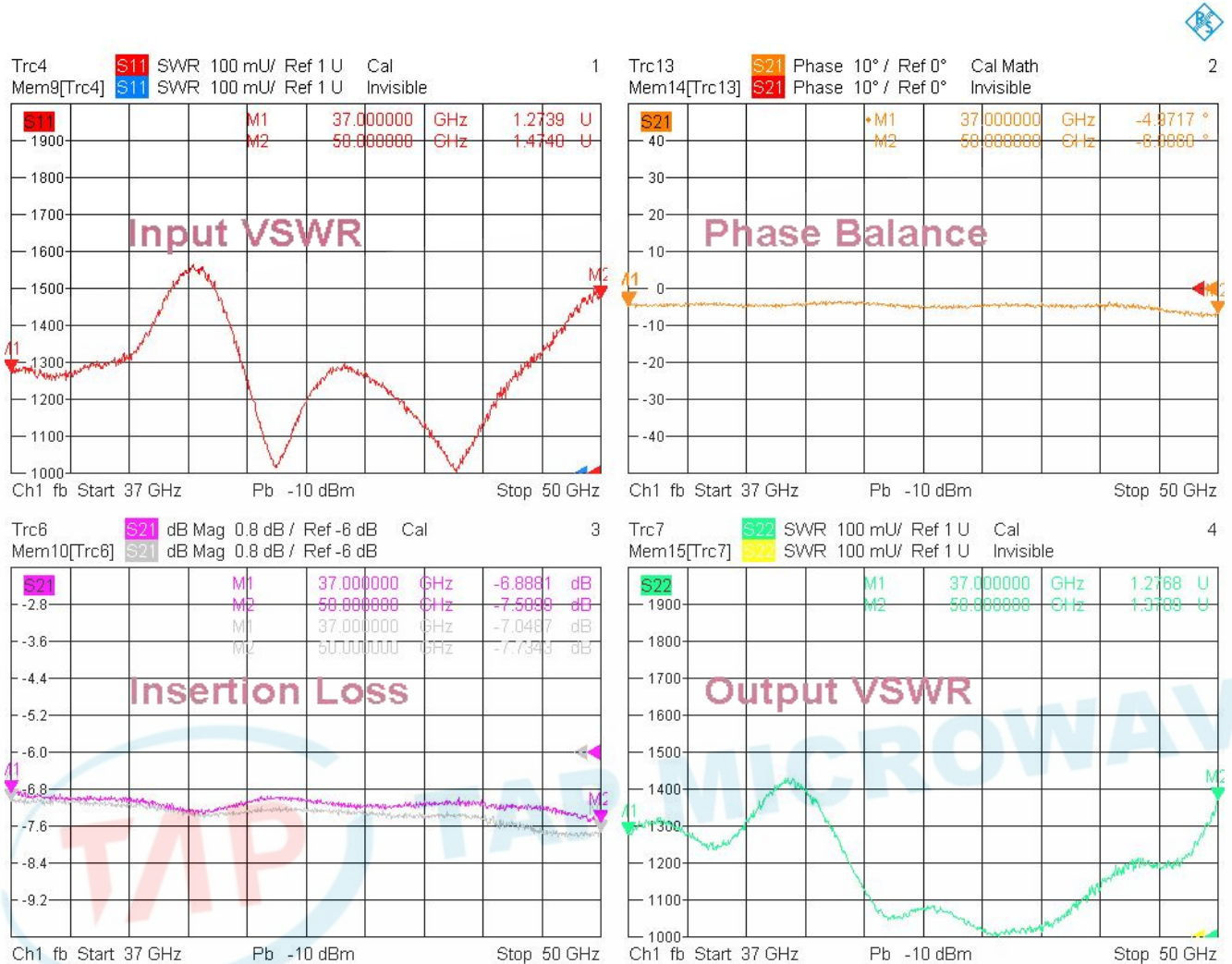

7/24/2024, 9:11 AM

### 2. Isolation

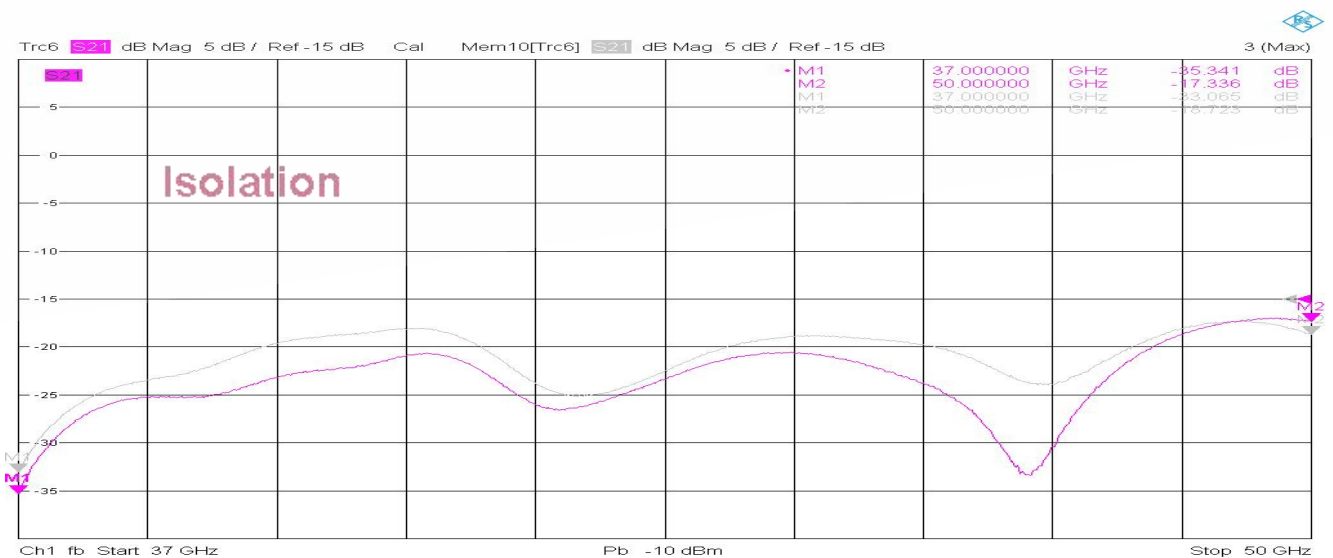

7/24/2024, 9:11 AM

