

Model TPT00270A15

Features

- Excellent phase& amplitude balance
- Low Insertion Loss& VSWR
- High Isolation

Technical Data Sheet			
Frequency Range	0.01~27GHz	Finish	Painted Blue_ RAL #5007
Insertion Loss	≤1.9dB	Connector Body	Passivated Stainless Steel
Coupling Factor	≤15±1.0dB	Housing	Aluminum, 6061 T6 Clear Chem Conversion Film
Coupling Sensitivity	≤±1.4dB	Connector Pin	Beryllium Copper, Gold Plate
VSWR	Though ≤1.60:1	Solder	Lead Free, RoHS Compliant
¹ Power Handling	Incident ≤1Watt; Reflected ≤1Watt	Operating Temperature	-55~+85℃
Impedance	50Ω	Operating Humidity	Up to 95%,Non- Condensing
Port Connectors	2.92mm-Female	Weight	30g

¹Power Handling guaranteed when load's VSWR within 1.50:1.

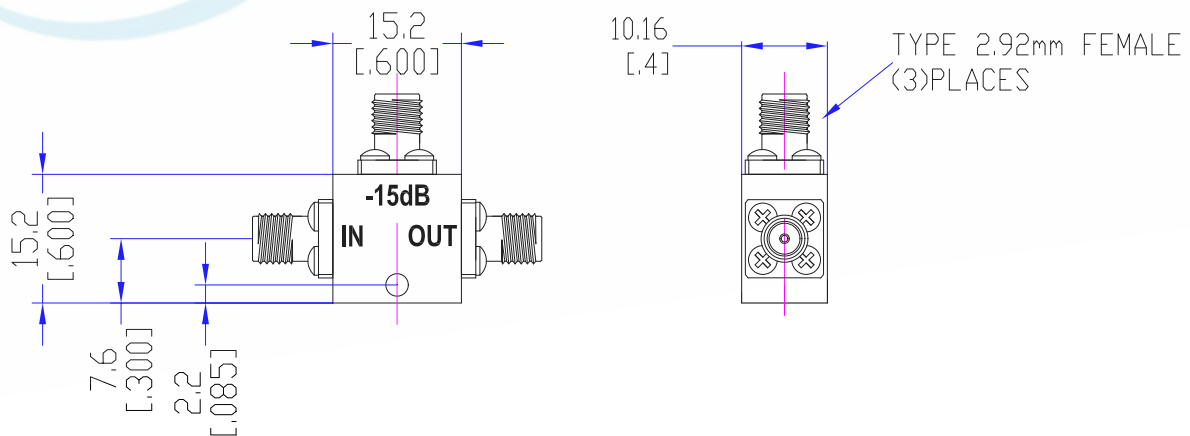

Typical Performance

1. Insertion Loss, Coupling Factor & Sensitivity, Isolation, VSWR

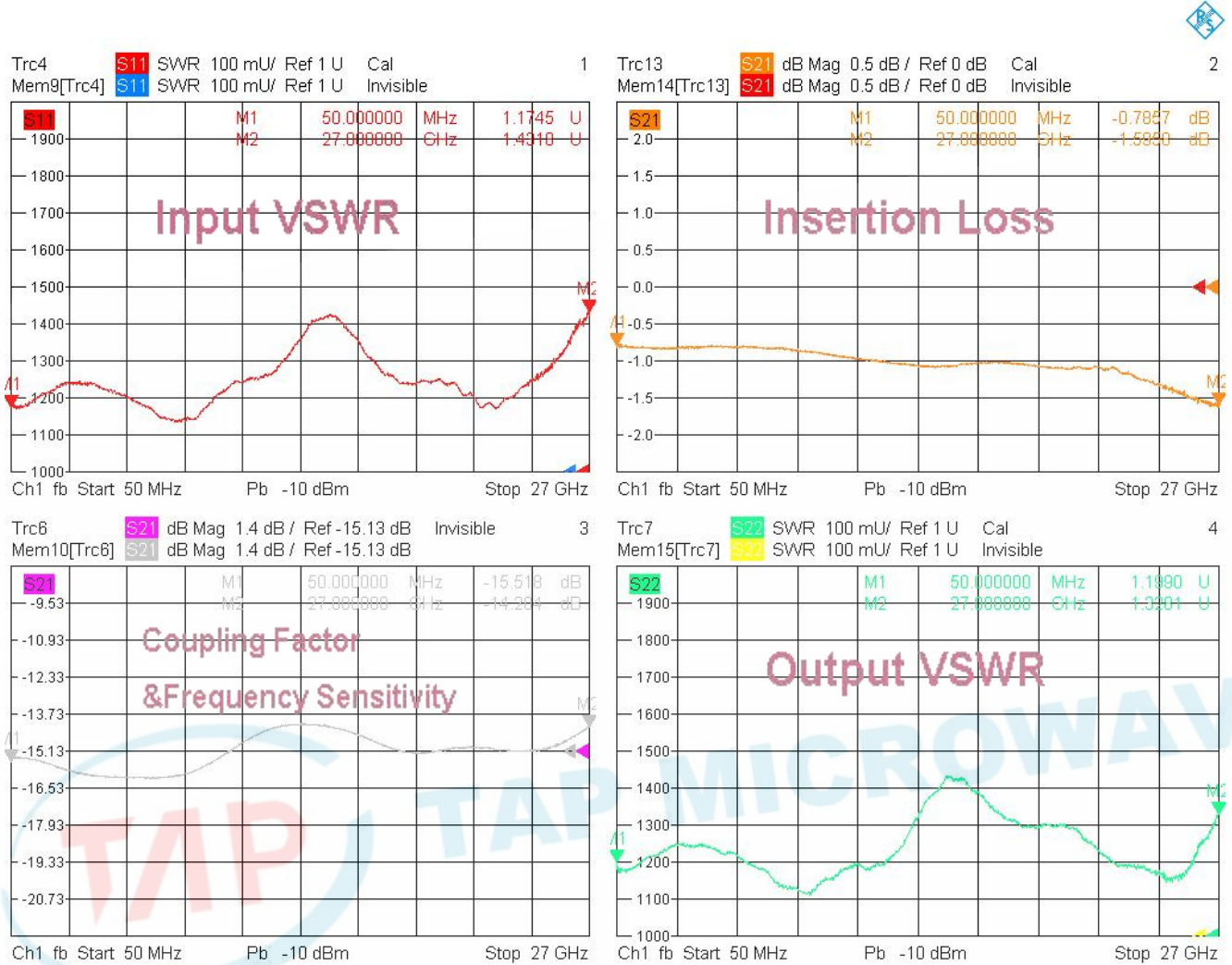

9/29/2022, 4:03 PM

