

Model TPT00400A15

Features

Excellent phase & amplitude balance
Low Insertion Loss & VSWR
High Isolation

Technical Data Sheet			
Frequency Range	0.01~40GHz	Finish	Painted Blue_ RAL #5007
Insertion Loss	≤2.0dB	Connector Body	Passivated Stainless Steel
Coupling Factor	≤15±1.5dB	Housing	Aluminum, 6061 T6 Clear Chem Conversion Film
Coupling Sensitivity	≤±1.6dB	Connector Pin	Beryllium Copper, Gold Plate
VSWR	Though ≤1.70:1	Solder	Lead Free, RoHS Compliant
¹ Power Handling	Incident ≤1Watt; Reflected ≤1Watt	Operating Temperature	-55~+85°C
Impedance	50Ω	Operating Humidity	Up to 95%, Non- Condensing
Port Connectors	2.92mm-Female	Weight	30g

¹Power Handling guaranteed when load's VSWR within 1.50:1.

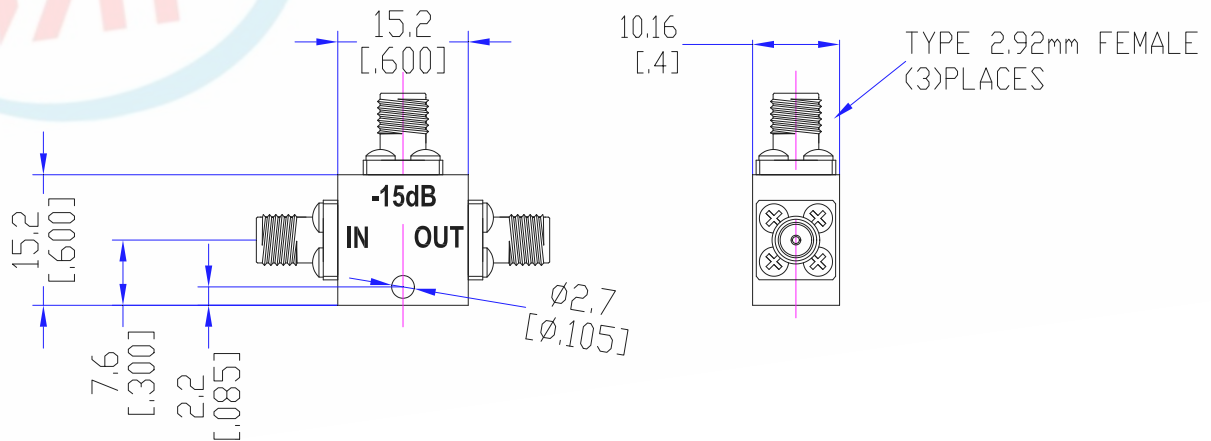

Typical Performance

1. Insertion Loss Coupling Factor & Sensitivity, Isolation, VSWR

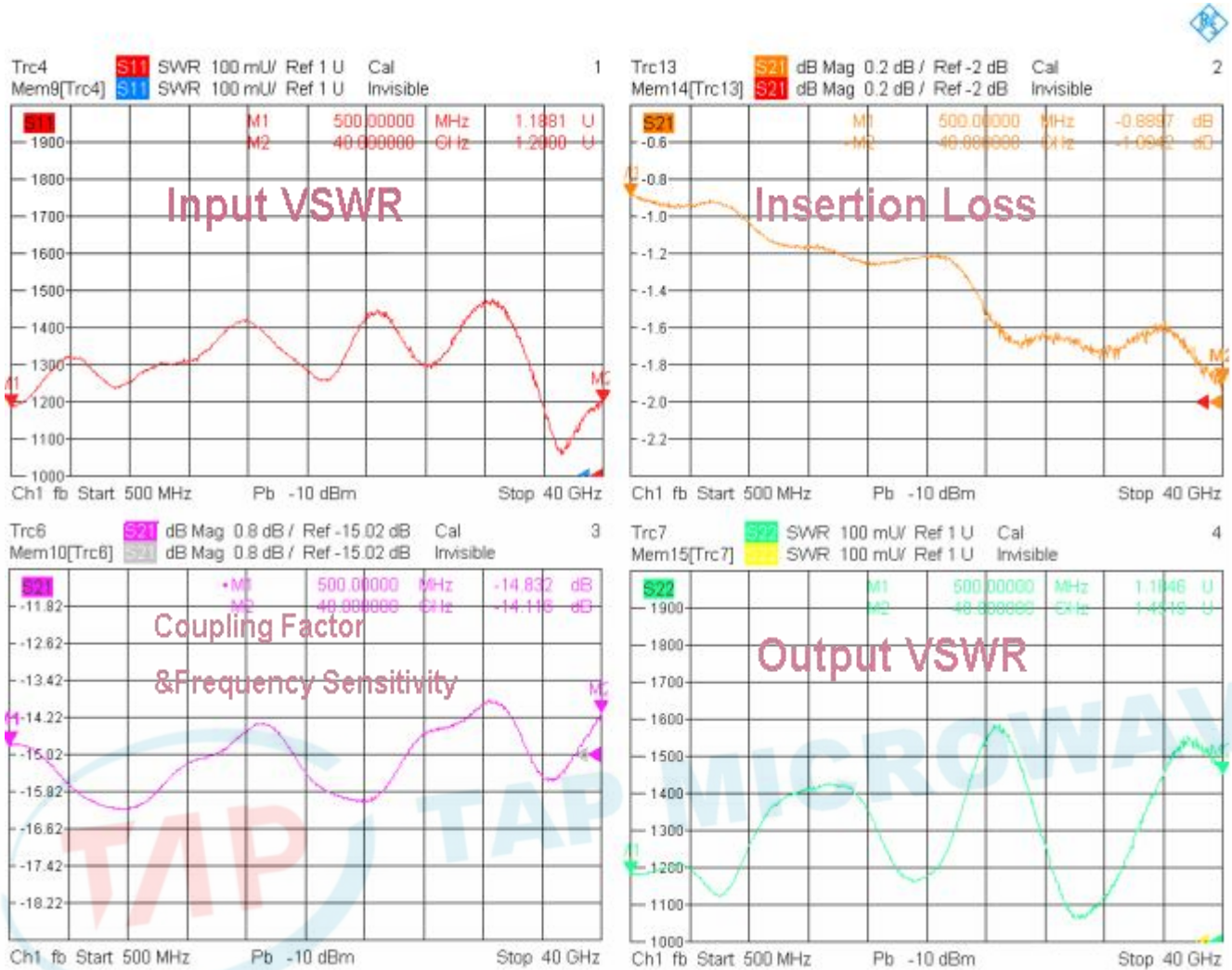

9/7/2021, 10:26 AM

