

Model TPD00200A4

Features

Excellent phase & amplitude balance
Low Insertion Loss & VSWR
High Isolation

Technical Data Sheet			
Frequency Range	DC~20GHz	Finish	Painted Blue_ RAL #5007
Insertion Loss	≤3.4dB (Above 12.04dB Split)	Connector Body	Passivated Stainless Steel
VSWR	Input ≤1.60:1 Output ≤1.60:1	Housing	Aluminum, 6061 T6 Clear Chem Conversion Film
Isolation	-----	Connector Pin	Beryllium Copper, Gold Plate
Amplitude Balance	≤±0.8dB	Solder	Lead Free, RoHS Compliant
Phase Balance	≤±8°	Operating Temperature	-55~+85°C
¹ Power Handling	Forward ≤0.2Watt; Reversed ≤0.2Watt	Operating Humidity	Up to 95%, Non- Condensing
Impedance	50Ω	Weight	40g
Port Connectors	SMA-Female		

¹Power Handling guaranteed when load's VSWR within 1.50:1.

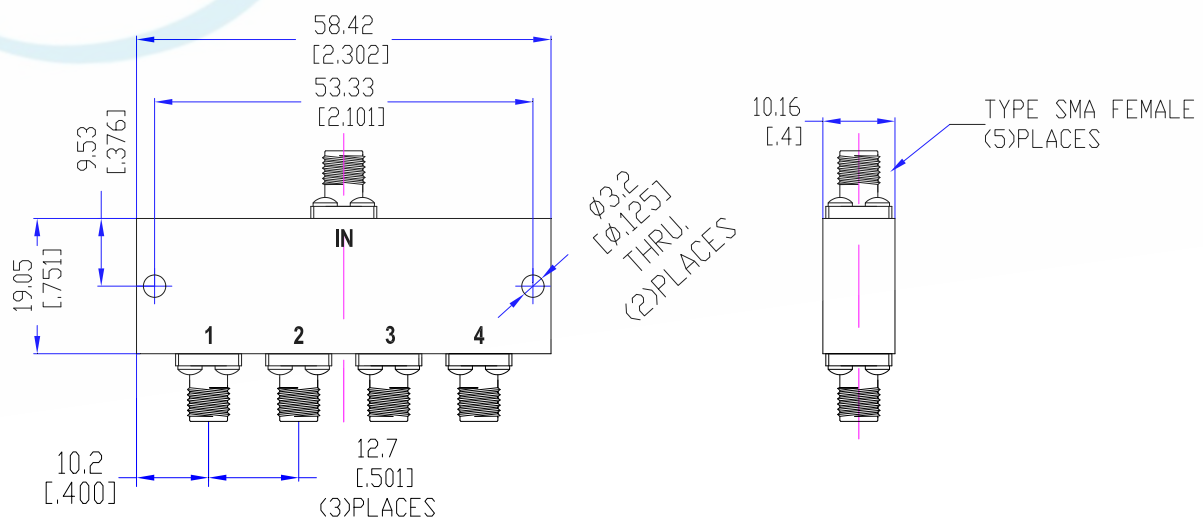

Typical Performance

1. Insertion Loss, Amplitude &Phase Balance, VSWR

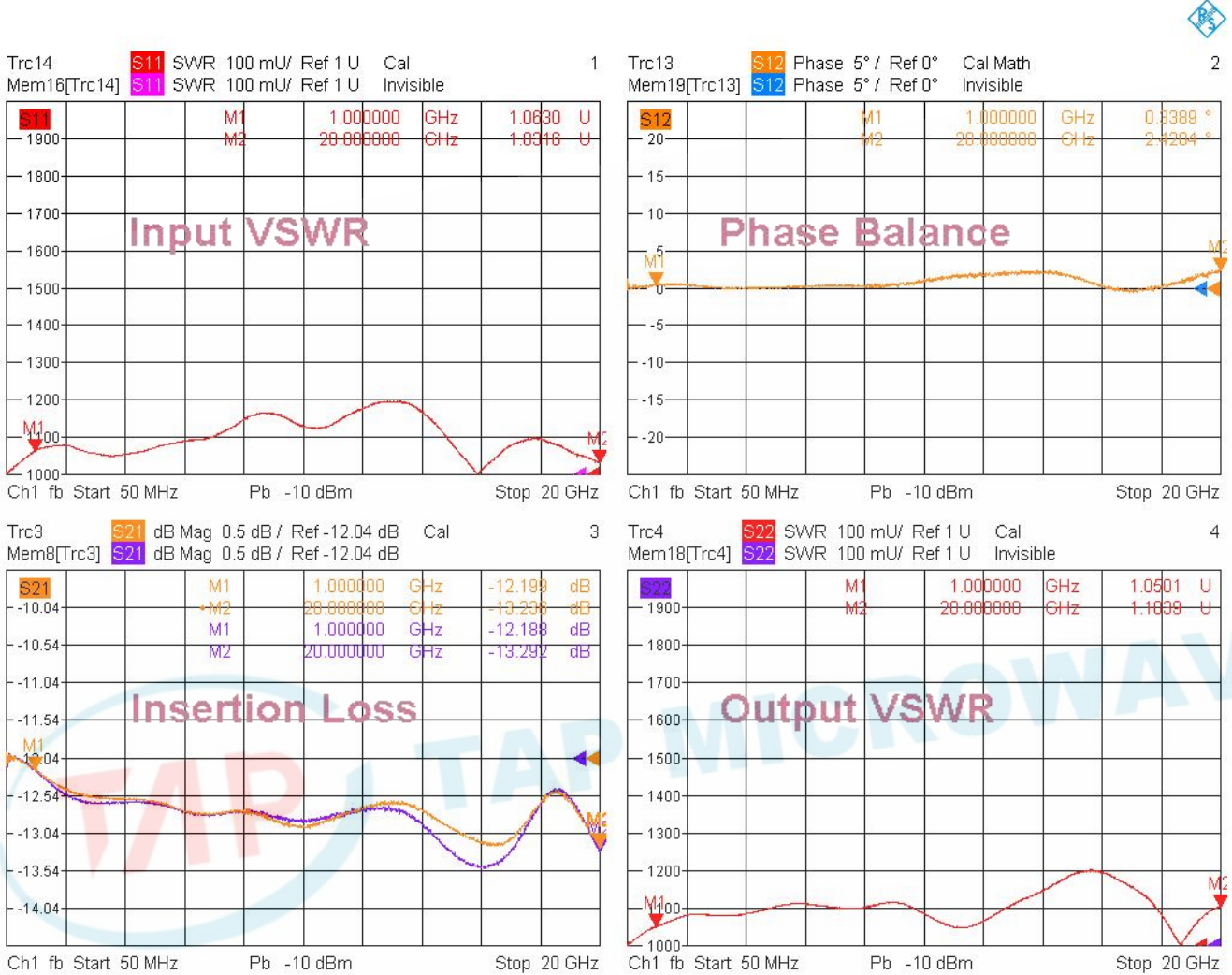

8/1/2024, 11:24 AM

