

Model TPD0827A2M

Features

Excellent phase & amplitude balance
 Low Insertion Loss & VSWR
 High Isolation

Technical Data Sheet			
Frequency Range	800~2700MHz	Finish	Natural oxygen
Insertion Loss	≤0.5dB (Above 3.01dB Split)	Connector Body	Brass, Tri-Alloy Plate
VSWR	Input ≤1.25:1 Output ≤1.20:1	Housing	Aluminum, 6061 T6 Clear Chem Conversion Film
Isolation	≥22dB	Connector Pin	Beryllium Copper, Gold Plate
Amplitude Balance	≤±0.2dB	Solder	Lead Free, RoHS Compliant
Phase Balance	≤±2°	Operating Temperature	-55~+85°C
¹ Power Handling	Forward ≤30Watt; Reversed ≤1Watt	Operating Humidity	Up to 95%, Non-Condensing
Impedance	50Ω	Weight	40g
Port Connectors	Input: SMA-Male Output: SMA-Female		

¹Power Handling guaranteed when load's VSWR within 1.50:1.

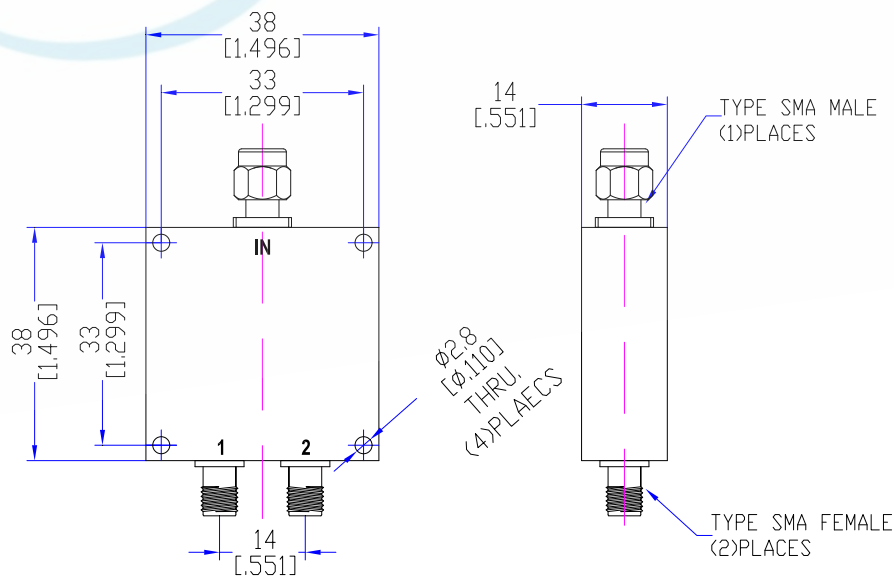

Typical Performance

1. Insertion Loss, Amplitude & Phase Balance, VSWR

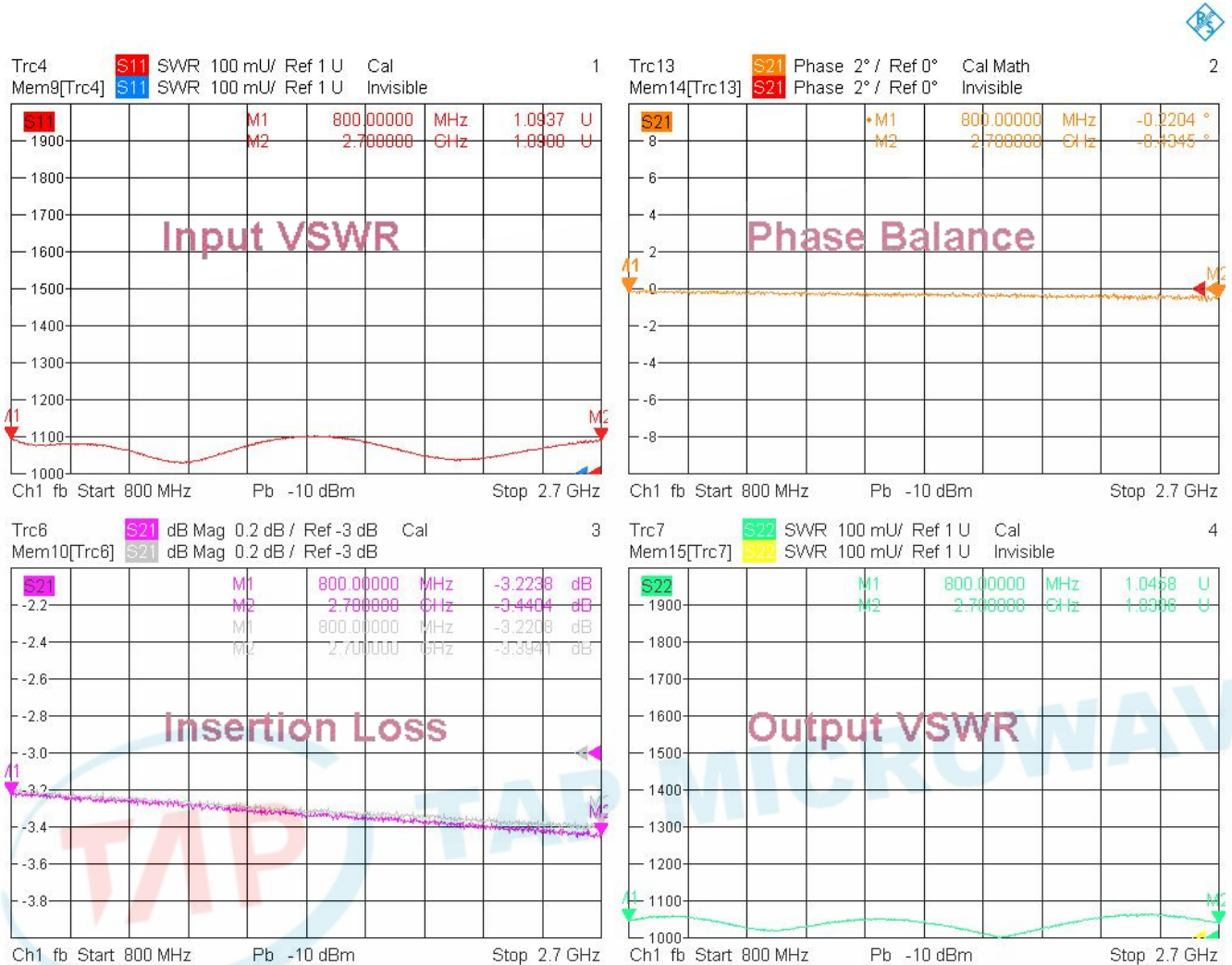

2. Isolation

