

## Model TPD20180A2T

### Features

- Excellent phase & amplitude balance
- Low Insertion Loss & VSWR
- High Isolation

Technical Data Sheet			
Frequency Range	2~18GHz	Finish	Painted Gray
Insertion Loss	≤1.2dB (Above 3.01dB Split)	Connector Body	Passivated Stainless Steel
VSWR	Input ≤1.50:1 Output ≤1.50:1	Housing	Aluminum, 6061 T6 Clear Chem Conversion Film
Isolation	≥18dB	Connector Pin	Beryllium Copper, Gold Plate
Amplitude Balance	≤±0.3dB	Solder	Lead Free, RoHS Compliant
Phase Balance	≤±5°	Operating Temperature	-55~+85°C
<sup>1</sup> Power Handling	Forward ≤30Watt; Reversed ≤1Watt	Operating Humidity	Up to 95%, Non-Condensing
Impedance	50Ω	Weight	30g
Port Connectors	SMA-Female		

<sup>1</sup>Power Handling guaranteed when load's VSWR within 1.50:1.

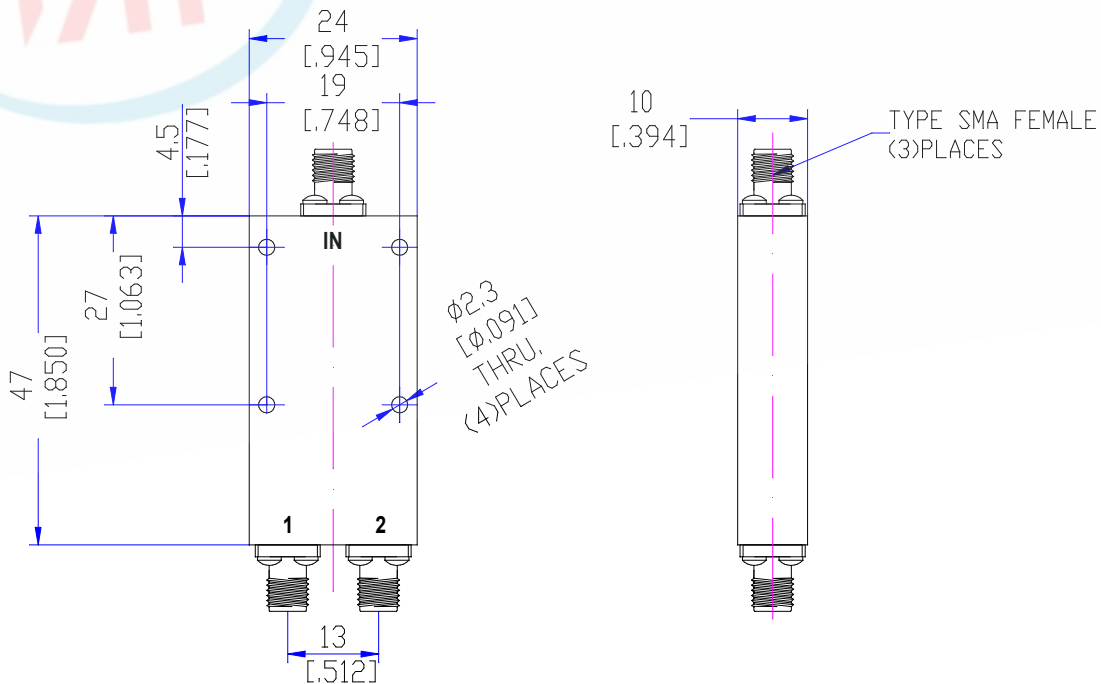

## Typical Performance

### 1. Insertion Loss, Amplitude & Phase Balance, VSWR

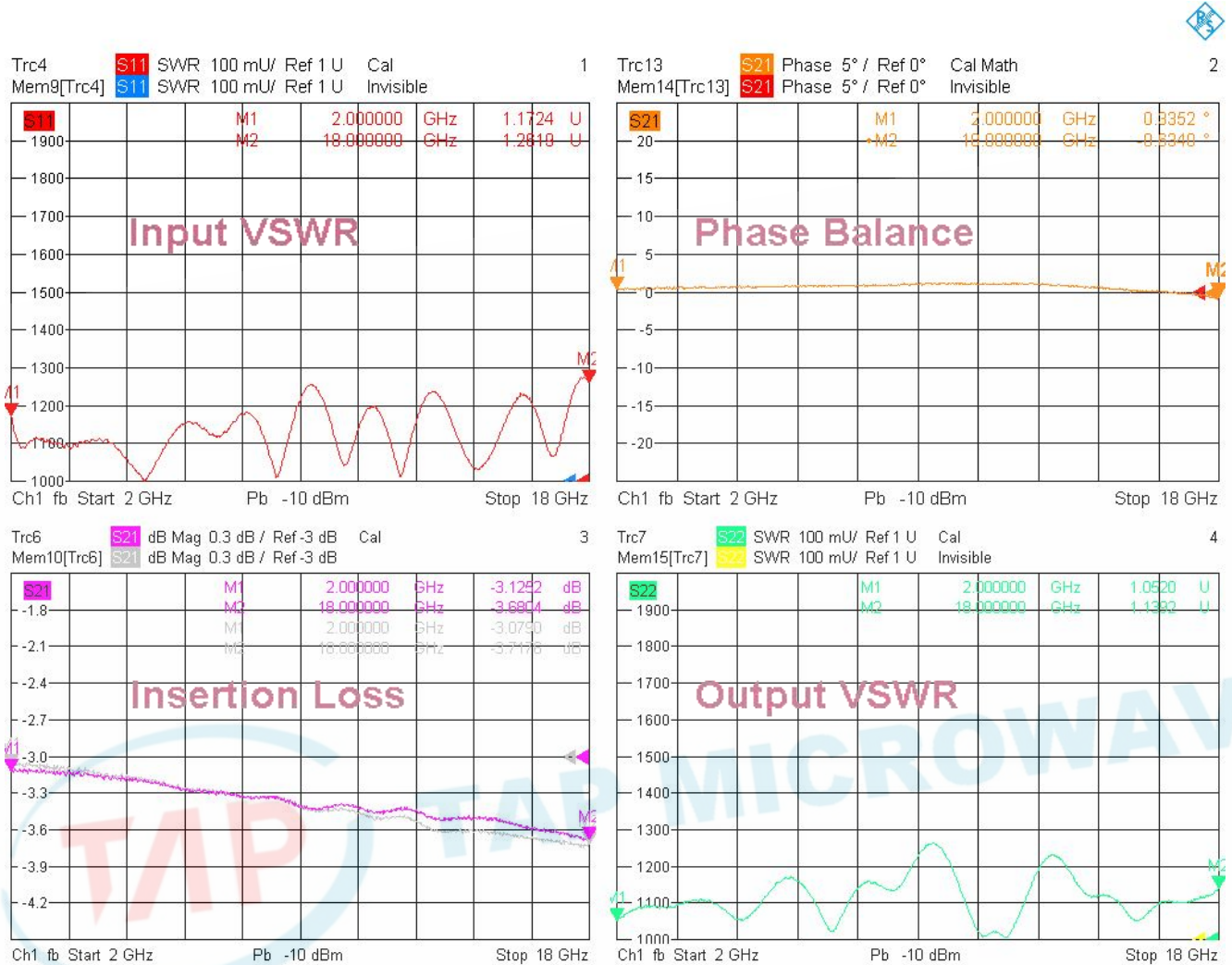

11/13/2023, 11:37 AM

### 2. Isolation

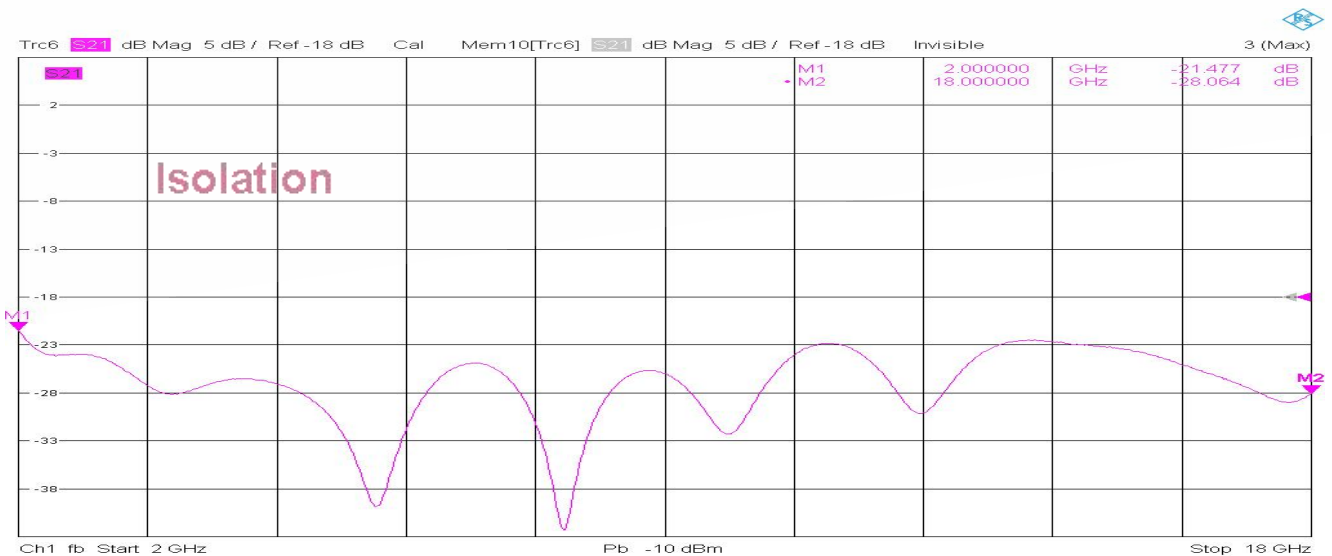

11/13/2023, 11:37 AM

